

INSTRUMENT PANEL

Article Text

1995 Cadillac Concours

For Ace Mechanics 123 Main Street San Diego Ca 92126

Copyright © 1997 Mitchell International

Friday, November 28, 2003 07:27PM

ARTICLE BEGINNING

1995 ACCESSORIES & SAFETY EQUIPMENT

General Motors Corp. Switches & Instrument Panels

"E" Body

Cadillac: Concours, DeVille

WARNING: Before attempting ANY repairs involving steering column or related components, see SERVICE PRECAUTIONS and DISABLING & ACTIVATING AIR BAG SYSTEM in the AIR BAG RESTRAINT SYSTEM article.

DESCRIPTION & OPERATION

Instrument Panel Cluster (IPC) components include Climate Control Center (CCC), Fuel Data Center (FDC) and speedometer cluster. Speedometer cluster consists of speedometer, tachometer (analog only), odometer(s), fuel gauge, warning indicator lights and Driver Information Center (DIC). See Figs. 1 and 2.

The IPC is the heart of the vehicle computer systems. IPC has an internal microprocessor which is the center link between all other computer components/modules in the vehicle's computer system. All component systems and sensors relay input to the IPC through the serial data line or are monitored directly by the IPC.

A twilight sentinel lighting system can be set to control operation of exterior lighting in relation to ambient light (daylight). This lighting system can also be set to keep exterior lights on for a pre-selected amount of time after ignition is turned off. This lighting system uses a photocell, twilight sentinel module assembly and control switch mounted beside headlight switch.

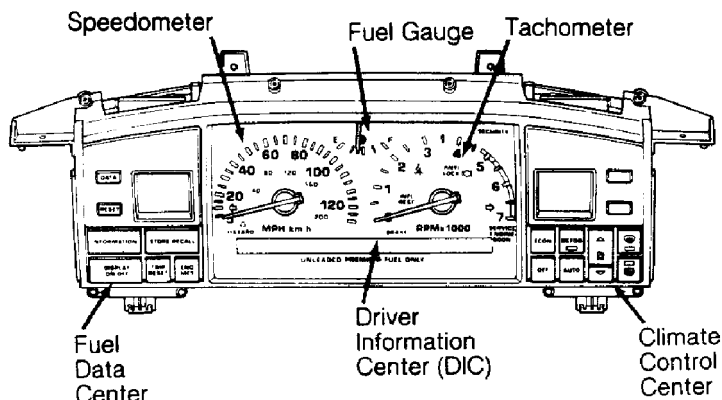

93F41124

Fig. 1: View Of Analog Instrument Cluster Panel
Courtesy of General Motors Corp.

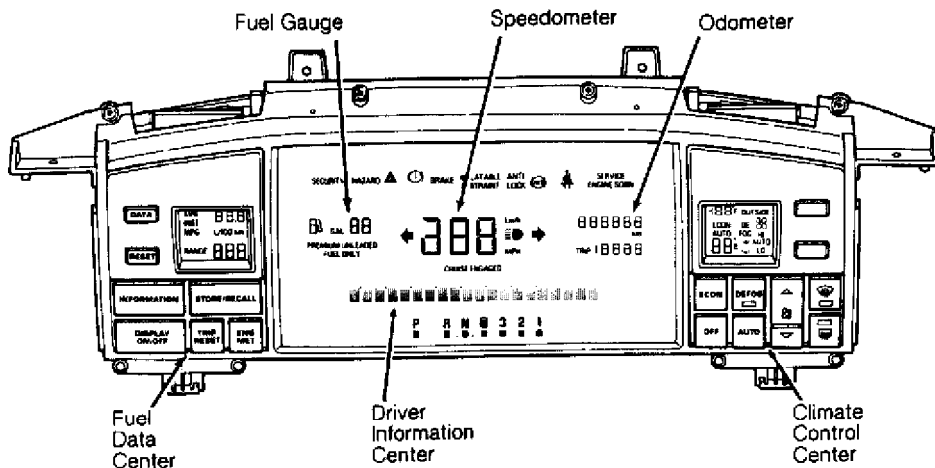

Fig. 2: View Of Electronic Instrument Cluster Panel
 Courtesy of General Motors Corp.

CLIMATE CONTROL CENTER

Climate Control Center (CCC) displays outside temperature, inside temperature, system mode, blower speed, and rear defogger information. The CCC is also used for entering and displaying self-diagnostics.

DRIVER INFORMATION CENTER

Driver Information Center (DIC) is 20-character dot matrix display area in the bottom center portion of cluster. See Figs. 1 and 2. The DIC is used to display warning/status messages and driver selectable information.

INFORMATION Button

Pressing the INFORMATION button begins DIC displays for Engine RPM, Coolant Temperature, Battery Voltage, Oil Life Index, Fuel Used and all monitored systems status/warning messages.

DISPLAY ON/OFF Button

Pressing DISPLAY ON/OFF button turns off illuminated displays except for speedometer, turn signals, and cruise engaged indicator. All systems continue working, but are not visible to driver. Press button again to resume illumination of all displays.

Oil Life Index

Pressing INFORMATION button will cycle messages until "Oil Life Index" is displayed. The numbers displayed represent the percentage of useful oil life remaining. When oil life reaches zero percent, the message CHANGE ENGINE OIL will display. After an oil change, reset display by pressing INFORMATION button until "Oil Life Index" is displayed, and then press and hold STORE/RECALL button for

about 5 seconds. When properly reset, 100 percent will display.

STORE/RECALL Button

Pressing this button allows driver to acknowledge message(s) on DIC display and store it in IPC memory. All stored messages during an ignition cycle can be reviewed one at a time by pressing Store/Recall Button. Messages are erased by pressing Display On/Off button or by turning off ignition.

FUEL DATA CENTER

Digital readout display located to left of speedometer cluster is for fuel economy data. Range is displayed as the estimated remaining mileage with current fuel level and current fuel economy. When range calculations fall below 40 miles, display will read "LO". Average fuel economy is M.P.G. since display was last reset. Instantaneous fuel economy is M.P.G. in the last few seconds. Average or instantaneous fuel economy are obtained by pressing DATA button. Press RESET to reset all fuel data figures when refueling.

SPEEDOMETER CLUSTER

Speedometer cluster, located in center of instrument cluster, contains a speedometer, tachometer (analog cluster only), odometer, fuel gauge, gear position indicator and warning indicator lights. Analog cluster uses sweep needle gauges for speedometer, tachometer and fuel gauge. Electronic (digital) cluster uses a quartz mechanism to control display illumination. Displays on electronic cluster are illuminated by Blue/Green Vacuum Fluorescent (VF) indicators.

TWILIGHT SENTINEL LIGHTING SYSTEM

This lighting system will automatically turn on headlights when ambient lighting (daylight) is reduced to point at which headlights are necessary. This is accomplished through use of a photocell mounted in defroster grille. System will operate with headlight switch in OFF position, ignition on and twilight sentinel switch in ON position. This lighting system can also be pre-set to remain on for up to 3 minutes after ignition is turned off. Although this system operates through original headlight switch circuits, it operates independently of headlight switch. Headlight switch operates exterior lighting system independently of twilight sentinel system.

WARNING INDICATOR LIGHTS

Warning indicator lights in speedometer cluster alert driver of various vehicle conditions. All warning indicator lights illuminate during engine start as a bulb check. Warning indicator lights include BRAKE, SERVICE ENGINE SOON, ANTI-LOCK brake system, INFLATABLE INSTRUMENT

RESTRAINT, SECURITY, and SAFETY BELT.

AIR BAG PRECAUTIONS

CAUTION: When battery is disconnected, vehicle computer and memory systems may lose memory data. Driveability problems may exist until computer systems have completed a relearn cycle. See the COMPUTER RELEARN PROCEDURES article in the GENERAL INFORMATION section before disconnecting battery.

The following precautions must be observed when working on vehicles equipped with Supplemental Inflatable Restraint (SIR) air bag systems:

- * Before performing any instrument panel testing, diagnosis or repair, disable SIR system by disconnecting negative battery cable and Yellow 2-pin connectors at base of steering column and behind trap door in glove box.
- * Wait 20 minutes before making SIR repairs to enable SIR system Diagnostic Energy Reserve Module (DERM) to power down. DERM retains enough voltage to deploy air bag for a short time after battery voltage is disconnected.
- * To avoid accidental air bag deployment, avoid any Yellow SIR wiring harnesses when trouble shooting, repairing or replacing instrument panel components. All SIR wiring harnesses are color-coded Yellow.

HANDLING PRECAUTIONS

CAUTION: When handling Electrostatic Discharge (ESD) sensitive electronic parts, specific care should be given to avoid damaging components. Specific care is as follows:

1) Discharge personal static electricity by momentarily touching metal grounding point on vehicle before coming in contact with electronic components.

2) NEVER touch terminals on components or connectors with fingers or metal tools. When disconnecting connectors, NEVER let metal tool contact any exposed terminal.

3) NEVER jumper, ground or use test meter probes on components or connectors unless specified in diagnostic procedures. Always connect ground lead first.

4) DO NOT remove solid-state components from protective packaging until ready for installation. Touch packaging to ground before opening.

5) DO NOT bump or drop component. DO NOT lay component on metal work bench, electrical metal objects or other electrically operated components, such as radio, TV or oscilloscope.

INSTRUMENT PANE

Components Possibly Damaged By ESD:

- * Electronic Brake (& Traction) Control Module (EBCM Or EBTCM)
- * Diagnostic Energy Reserve Module (DERM)
- * Powertrain Control Module (PCM)
(including PROM, CAL-PAK or MEM-CAL)
- * Chime Module & Cruise Control Module
- * Electronic Spark Control Module
- * Instrument Cluster Panel (IPC)
- * Heater Ventilation Air Conditioning (HVAC) Electronic
A/C-Heater Controllers & Modules
- * Twilight Sentinel Amplifier
- * Radio & Theft Deterrent Modules

COMPONENT TESTING

WARNING: Before attempting ANY repairs involving steering column or related components, see SERVICE PRECAUTIONS and DISABLING & ACTIVATING AIR BAG SYSTEM in the AIR BAG RESTRAINT SYSTEM article before attempting any repairs involving steering column or related components.

CAUTION: When battery is disconnected, vehicle computer and memory systems may lose memory data. Driveability problems may exist until computer systems have completed a relearn cycle. See the COMPUTER RELEARN PROCEDURES article in the GENERAL INFORMATION section before disconnecting battery.

BRAKE SYSTEM WARNING INDICATOR

Indicator Diagnosis

1) Battery voltage is applied to the BRAKE indicator when the ignition switch is in RUN, BULB TEST or START position. Ground for the circuit is supplied through any of several switches which monitor low brake fluid level, unequal brake pressure and parking brake lever engagement.

2) BRAKE indicator may also come on when a problem is detected in anti-lock brake system (if equipped). If there is a problem with BRAKE indicator functioning, check appropriate switches and circuits. See WIRING DIAGRAMS.

CRUISE CONTROL SWITCH TEST

For testing information on cruise control, see the CRUISE CONTROL SYSTEM article.

HEADLIGHT SWITCH TEST (WITH AUTOMATIC TWILIGHT SENTINEL)

For testing information on Twilight Sentinel system, see the HEADLIGHTS - AUTOMATIC TWILIGHT SENTINEL (except Concours) article.

FUEL SENDING UNIT TEST

See FUEL GAUGE INOPERATIVE/INACCURATE under IPC TESTS.

IPC TESTS

IPC Dimming Problem

1) IPC monitors parking light input circuit (Brown wire) from headlight switch to determine when headlight/parking lights are on. When lights are on, headlight switch converts dimming control output to Pulse Width Modulation (PWM) signal.

2) This PWM signal is distributed to interior lighting units (i.e., radio, IPC, console, etc.). IPC "sees" parking lights "on" input (II94) at IPC terminal D3. IPC then knows when to monitor dimming value (ID42) at IPC terminal C10 to control dimming of IPC and radio Vacuum Fluorescent (VF) displays.

3) To test dimming, enter self-diagnostics and record all trouble codes. See ENTERING SELF-DIAGNOSTICS under SELF-DIAGNOSTICS. If Code I022 is set, repair this code problem before proceeding. See TROUBLE CODES under SELF-DIAGNOSTICS. Exit self-diagnostics. Turn headlights on. Rotate dimmer switch while noting operation of backlighting for radio, IPC buttons, PRNDL indicator, etc., and all VF Green displays.

4) If any or all bulb type lights fail to illuminate or dim, or lights stay on continuously, go to step 13). If all bulb type backlighting lights do illuminate, go to next step.

5) Notice VF Green lighting. If radio VF dims correctly but IPC remains bright, replace IPC. See INSTRUMENT PANEL CLUSTER under REMOVAL & INSTALLATION. If radio VF and IPC are bright and do not change with dimmer, go to next step. If IPC dims, but radio does not, go to step 7). If radio dims but IPC is blank, go to step 11).

6) Enter diagnostics and select input parameter II94. Turn headlights on. If II94 reads HI, replace IPC. See INSTRUMENT PANEL CLUSTER under REMOVAL & INSTALLATION. If II94 reads LO, repair open in Brown wire circuit between IPC and splice S411. S411 is located to left of rear seat bottom section, enclosed in a flat plastic harness cover. S411 is located inside flat cover about 5 inches from bottom of cover.

7) If IPC does dim, but radio does not and radio remains blank, replace radio control head. If radio remains full bright, enter self-diagnostics and select IPC OVERRIDE IS45 (VF Output). See ENTERING SELF-DIAGNOSTICS under SELF-DIAGNOSTICS. Locate radio control head connector C2 (7-pin) terminal No. 3 (Purple/White wire). This operation may require removal of radio control head from dash.

vehicle is console equipped.

8) Using DVOM, backprobe radio control head connector C2 (7-pin) terminal No. 3 (Purple/White wire) while moving value of IS45 from 00 to 99. At "99" value, IPC should be at full bright and DVOM should read about zero volts. At "00" value, IPC should be at maximum dim (Black out) and DVOM should read about 5 volts.

9) If voltage readings are as described, go to next step. If voltage readings are not as described, repair open or short in Purple/White wire between IPC and radio control head. If no open or short is found, replace IPC. See INSTRUMENT PANEL CLUSTER under REMOVAL & INSTALLATION.

10) Leave headlights on and measure voltage at radio control head connector C1 (9-pin) terminal No. 6 or 7. (Brown wire). If voltage is 10 volts or more, replace radio control head. If voltage is less than 10 volts, repair open in Brown wire between radio and connector S409. Connector C203 contains 23 terminals and is located to right of steering column, near rear of radio control head. Splice S409 is located in Brown wire between radio head terminal No. 6 or 7 and fuse D11.

11) Disconnect radio control head connector C2 (7-pin). If IPC illuminates, replace radio control head. If IPC remains blank, use DVOM to measure voltage at radio control head harness connector C2 terminal No. 5 (Orange/Black wire).

12) If voltage reading is 10 volts or more, replace IPC. See INSTRUMENT PANEL CLUSTER under REMOVAL & INSTALLATION. If voltage reading is less than 10 volts, repair open or short to ground in Orange/Black wire circuit between IPC and radio control head. If wire is okay, replace IPC. See INSTRUMENT PANEL CLUSTER under REMOVAL & INSTALLATION.

13) If none of the bulb type backlighting lights are on, check fuse D13 and go to next step. If all bulb type backlighting lights stay on continuously, repair short to voltage in Gray wire circuit between IPC and headlight switch. If only some lights illuminate, repair open in Gray wire circuit or Black ground wire circuit, or replace bad bulbs. See WIRING DIAGRAMS.

14) Check for voltage at trunk fuse block fuse D13 with headlights on. If fuse is blown, go to next step. If no voltage exists, repair open in power feed to fuse. If voltage exists, repair open between trunk fuse D13 and splice S411. Splice S411 is located left of rear seat bottom section, enclosed in flat plastic harness cover. S411 is located inside flat cover about 5 inches from bottom of cover.

15) Turn headlights off. Disconnect 4-terminal connector at headlight switch. See HEADLIGHT/TWILIGHT SENTINEL SWITCH MODULE under REMOVAL & INSTALLATION. Remove Gray wire terminal from 4-terminal connector cavity. Reconnect 4-terminal connector to headlight switch (without Gray wire). Replace fuse and turn headlights on. Rotate dimmer switch through complete travel.

16) If bulb backlighting now operates, go to next step. If bulb backlighting is still inoperative, repair short to ground in Brown wire circuit between headlight switch and IPC. If no short exists, replace headlight switch and retest.

17) Turn off headlights. Disconnect 4-terminal connector from headlight switch. Reinstall Gray wire to 4-terminal connector. Reconnect headlight switch connector. Turn headlights on. Rotate dimmer switch through complete travel.

18) If bulb backlighting is still inoperative, repair short to ground in Gray wire circuit between headlight switch and IPC. If bulb backlighting now operates, problem is intermittent. Recheck Gray and Brown wiring circuits for intermittent short. If no problem is found, replace headlight switch. See HEADLIGHT/TWILIGHT SENTINEL SWITCH MODULE under REMOVAL & INSTALLATION.

Fuel Gauge Inoperative/Inaccurate

1) Fuel level is displayed as a "filtered" fuel level measured in whole gallons (or liters). When IPC reads more than 18.9 gallons, it displays "F". All readings between 18.9 and 2 gallons will display in whole gallon numbers only. When IPC reads fuel level of 2.0 gallons, fuel gauge will display "E". When IPC reads fuel level of 1.0 gallon, "E" will flash and FUEL LEVEL VERY LOW message will display on DIC.

2) If display is operating in DISPLAY OFF mode and fuel level falls to less than 4 gallons, all displays will illuminate and become active again. DIC will display CHECK FUEL GAUGE.

3) Enter self-diagnostics and record all codes. See ENTERING SELF-DIAGNOSTICS under SELF-DIAGNOSTICS. If Code I041 is set, see CODE I041 OR I042 - BATTERY VOLTAGE TOO LOW OR TOO HIGH. If Code I041 is not set and fuel gauge operation is nonlinear or erratic, go to next step. If Code I041 is not set and fuel gauge always reads full, go to step 5). If Code I041 is not set and fuel gauge always reads empty, go to step 8).

4) Ensure all related terminal connections are good. Exit self-diagnostics. Remove fuel tank sending unit. If connector was disconnected during removal, reconnect sending unit to its harness connector, near filler tube on top of tank. Enter diagnostics to observe ID40 data value. Hand operate fuel sending unit float through full range of travel, watching for jumps or erratic data values. If sending unit does not move freely and/or data values jump, replace sending unit.

5) Note data value of ID40 (fuel level). If data value reading is of actual gallons in tank and is much different than IPC fuel gauge display, replace IPC. See INSTRUMENT PANEL CLUSTER under REMOVAL & INSTALLATION. If data value reading is 16 or more gallons, disconnect fuel tank sending unit connector.

6) If data value reading is now less than 2 gallons, go to next step. If data value reading is now less than 2 gallons, go to next step. If data value reading is now less than 2 gallons, go to next step.

short to voltage in Purple wire circuit. If a short is not found, replace IPC. See INSTRUMENT PANEL CLUSTER under REMOVAL & INSTALLATION.

7) Use DVOM to measure voltage at fuel sending unit harness connector between terminals "D" (Pink wire) and "F" (Black/White wire). If voltage is 10 volts or greater, replace sending unit. If voltage is less than 10 volts, repair open in Black/White wire from terminal "F" to ground.

8) Note data value of ID50 (ignition voltage to IPC reading). If voltage is 10 volts or more, note data value of ID40 (fuel level). If value is same as actual fuel level in tank (with more than 3 gallons in tank), replace IPC. See INSTRUMENT PANEL CLUSTER under REMOVAL & INSTALLATION. If value is less than 3 gallons, go to next step.

9) Turn ignition on, close all doors and turn radio on. With doors still closed, turn off ignition. If radio continues to play, go to step 12). If radio turns off, go to next step.

10) Repair open in power feed circuit (Pink wire) to Retained Accessory Power (RAP) module and fuel tank sending unit between splice S402 and trunk fuse block fuse A11. Splice S402 is located vertically behind left side of rear seat back, inside black tape wrapped harness, about 10 inches below top of cross panel. This is not "flat" type harness cover going into trunk. Splice S402 wire color is Pink.

11) Turn ignition on. Using DVOM, measure voltage between fuel sending unit harness connector terminals "D" (Pink wire) and "F" (Black/White wire). If voltage is 10 volts or more, go to next step. If voltage is less than 10 volts, repair open in Pink wire from splice S402 to fuel sending unit connector. See previous step for location of splice S402.

12) Use a jumper wire to connect fuel sending unit harness connector terminals "D" (Pink wire) and "E" (Purple wire). Note data value of ID40. If value is greater than 3 gallons, replace fuel sending unit. If value is less than 3 gallons, go to next step.

13) Measure voltage between IPC connector terminal C8 and ground. See Fig. 3. If voltage is less than 10 volts, repair open or short to ground in Purple wire between IPC and fuel sending unit harness connector terminal "E". If voltage is 10 volts or greater, check terminal contact. If contact is okay, replace IPC. See INSTRUMENT PANEL CLUSTER under REMOVAL & INSTALLATION.

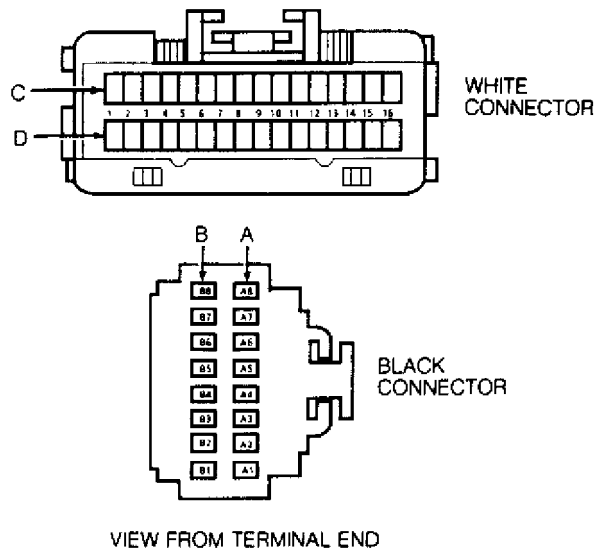

Fig. 3: Identifying IPC Harness Connector Terminals
 Courtesy of General Motors Corp.

Speedometer Inoperative/Inaccurate

1) Vehicle speed sensor signal is sent to PCM. PCM buffers signal and feeds a pulse train to IPC of 4000 pulses per mile through Brown wire circuit. IPC supplies system voltage to Brown wire circuit, and PCM pulses this circuit to ground to transmit speed signal. IPC uses this pulse data value to calculate and display vehicle speed.

2) Enter self-diagnostics. See ENTERING SELF-DIAGNOSTICS under SELF-DIAGNOSTICS. If Code E024 is set, repair this problem first. See CODE E024 in appropriate G - TESTS W/CODES article in the ENGINE PERFORMANCE section.

G - TESTS W/CODES - 4.6L - Concours

G - TESTS W/CODES - 4.9L - DeVille

If Code E024 is not set, raise drive wheels and properly support vehicle. Start engine and re-enter self-diagnostics if necessary.

3) Select IPC data parameter ID60 (vehicle speed). Put shifter in Drive position, and allow wheels to rotate at engine idle. If parameter ID60 data value is zero, go to step 5). If parameter ID60 data value is greater than zero, compare data value to speedometer display. If speedometer is inoperative, replace IPC. See INSTRUMENT PANEL CLUSTER under REMOVAL & INSTALLATION. If speedometer is about 1.07 times more than ID60 value, see IPC MALFUNCTION SYMPTOMS under SELF-DIAGNOSTICS.

4) If one or both readings are erratic and speedometer display is fluctuating while ID60 is constant speed, replace IPC. If ID60 is fluctuating with speedometer display, check terminal connections and wiring circuit for intermittent problem. Check if Brown wire is near secondary ignition wires, and move it as required.

5) Using DVOM with negative probe connected to ground, backprobe IPC White connector terminal C4 while wheels are turning. See Fig. 3. If voltage varies with speed, check connections at IPC terminal C4. If connections are good, replace IPC. See INSTRUMENT PANEL CLUSTER under REMOVAL & INSTALLATION.

6) If voltage is fixed at zero volts, go to next step. If voltage is fixed at 12 volts, turn engine off. Turn ignition on and disconnect PCM connector C2. See Fig. 4 or 5. PCM is mounted to right kick panel. Using DVOM connected to ground, measure voltage at PCM connector C1 terminal 1B11 (4.6L) or connector C2 terminal 2B11 (4.9L). If battery voltage is present, replace PCM. If zero voltage is present, repair open in Brown wire circuit between IPC and PCM.

7) Turn engine off. Turn ignition on. Disconnect PCM connector C2. Using DVOM with negative probe connected to ground, backprobe IPC connector terminal C4. See Fig. 3. If DVOM reading is now system voltage, replace PCM. If DVOM reading is zero volts, turn ignition off. Disconnect IPC connector. Ensure PCM connector is still disconnected.

8) Using DVOM, measure resistance between IPC connector terminal C4 and ground. See Fig. 3. If resistance is less than 1000 ohms, repair short to ground in Brown wire. If resistance is 1000 ohms or more, check connections at IPC terminal C4. If connections are good, replace IPC. See INSTRUMENT PANEL CLUSTER under REMOVAL & INSTALLATION.

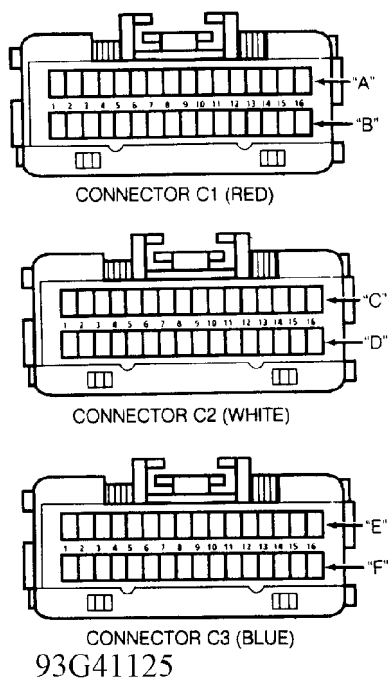

Fig. 4: Identifying PCM Connector Terminals (4.6L)
 Courtesy of General Motors Corp.

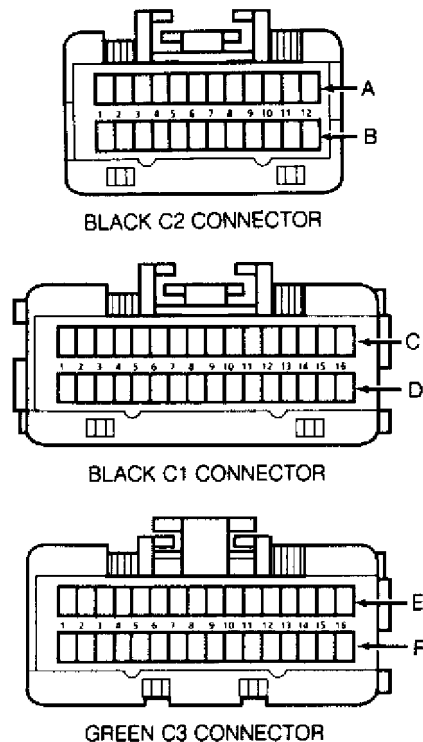

Fig. 5: Identifying PCM Connector Terminals (4.9L)
 Courtesy of General Motors Corp.

Tachometer Inoperative/Inaccurate (Analog Cluster)

1) Start engine and note tachometer reading. If tachometer is inoperative, go to step 5). If tachometer functions, go to next step.

2) Enter self-diagnostics. See ENTERING SELF-DIAGNOSTICS under SELF-DIAGNOSTICS. Select PCM parameter PD11 (RPM reading). Compare vehicle tachometer reading and PD11 reading while varying engine speed. If readings vary by more than 200 RPM, go to next step. If the 2 readings are always within 200 RPM of each other, go to step 4).

3) Check IPC connector terminal B1 for proper terminal contact. See Fig. 3. If terminal contact is okay, replace IPC. See INSTRUMENT PANEL CLUSTER under REMOVAL & INSTALLATION.

4) Ensure good terminal contact at all electrical connections. While wiggling harness, attempt to duplicate conditions under which failure occurred. If intermittent fluctuations occur, check for proper routing of White wire between IPC and ignition control module (4.6L) or distributor (4.9L).

5) With engine running, backprobe IPC connector terminal B1 to ground with a voltmeter set to AC voltage. If voltage is greater than 2 volts AC and voltage changes with RPM fluctuations, go to next step. If voltage is less than 2 volts AC and/or voltage does not change with RPM fluctuation, go to step 7).

6) Ensure proper terminal contact at IPC connector terminal B1 (White wire). If terminal contact is okay, replace IPC. See INSTRUMENT PANEL Article Text (p. 12)

INSTRUMENT PANEL CLUSTER under REMOVAL & INSTALLATION.

7) Turn ignition off. Disconnect Black IPC connector. Start engine. With a voltmeter on AC setting, measure voltage between IPC connector terminal B1 (White wire) and ground.

8) If voltage is less than 2 volts AC and/or voltage does not change with RPM fluctuation, go to next step. If voltage is greater than 2 volts AC and voltage changes with RPM fluctuations, repair White wire between IPC and ignition control module.

9) Ensure proper terminal contact at IPC terminal B1. If terminal contact is okay, replace IPC. See INSTRUMENT PANEL CLUSTER under REMOVAL & INSTALLATION.

OIL PRESSURE SWITCH TEST

1) Locate oil pressure switch at top of oil filter housing and disconnect connector. Using DVOM, with engine off, ensure continuity exists between switch terminal and switch ground. If continuity does not exist, replace switch.

2) With engine running at idle, continuity should not exist. If continuity exists with engine running, turn engine off immediately. Use manual oil pressure gauge tester to ensure oil pressure is greater than 5-10 psi at idle. If oil pressure is as specified, replace oil pressure switch.

SELF-DIAGNOSTICS

SELF-DIAGNOSTIC SYSTEM DESCRIPTION

The self-diagnostic system consists of several components. These components include the Powertrain Control Module (PCM), Instrument Panel Cluster (IPC), A/C Programmer (ACP), supplemental inflatable restraint system's Diagnostic Energy Reserve Module (DERM) and Road Sensitive Suspension (RSS) module (4.6L) or Speed Sensitive Suspension (SSS) module (4.9L). Also included in the self-diagnostic system on vehicles equipped with Anti-Lock Brake System (ABS) is the Electronic Brake Control Module (EBCM - 4.9L) or Electronic Brake & Traction Control Module (EBTCM - 4.6L).

In addition to monitoring a particular set of sensors and switches, the IPC maintains continuous communication with each of the other main components of the computer system. The other main components monitor other related sets of sensors and switches, reporting all system conditions to each of the main components continually through serial data line.

Should any IPC subsystem component exceed pre-programmed limits, the IPC will recognize the malfunction and may either exert some control over the component or, in the case of sensors, replace the sensor information with a standard or default value, which will allow the system to continue to function until servicing is performed.

As a result of these interactions between the IPC and a malfunctioning component, an alpha-numeric code, known as a trouble code, is often set in the IPC's memory. Trouble code identifies the malfunctioning component and code can be accessed by a service technician as an aid to diagnostic procedures. All trouble codes are displayed on the Climate Control Center (CCC).

In addition to monitoring the self-diagnostic system and displaying trouble codes, the IPC can be programmed by the service technician to perform specific diagnostic tests on individual components and systems. Results of these tests are displayed on CCC. This article covers accessing trouble codes and programming self-diagnostic system to perform specific diagnostic tests on IPC system components.

ENTERING SELF-DIAGNOSTICS

CAUTION: If performing self-diagnostics for longer than 30 minutes, connect a charger to vehicle battery to prevent draining battery.

Segment Check

This check is performed automatically upon entering self-diagnostic mode of Instrument Panel Cluster (IPC) computer. This check illuminates all display segments to verify proper operation. Failure of any display segment to illuminate during segment check may result in inaccurate diagnostic test results. If any display segment is inoperative, replace IPC before proceeding with self-diagnostic process.

Entering Self-Diagnostics

1) Turn ignition on. Simultaneously push and hold OFF and WARMER buttons on Climate Control Center (CCC). Continue to push OFF and WARMER buttons until segment check appears on CCC (after about 3 seconds). See Fig. 6.

2) When segment check appears (all segments illuminated), system has entered self-diagnostic mode. Release both buttons. Trouble codes, if stored, should be displayed. If system does not enter self-diagnostic mode, see SELF-DIAGNOSTIC SYSTEM CHECK. If no trouble codes are displayed, go to next step. If trouble codes are displayed, go to step 4).

3) If no codes are present, the message NO "X" CODES will display. "X" represents the main component system ("P", "I", "A", "R", "T" or "S"). If no codes are present but condition caused a Driver Information Center (DIC) message to be displayed, proceed to DIC MESSAGES under SELF-DIAGNOSTICS. If a serial data line communication problem exists, the message NO "X" DATA will display until that main system component ("X") communication problem line is repaired or replaced.

4) Each trouble code consists of a main component system abbreviation letter, followed by 3 digit code number, followed by letter "C" or "H" (for current or history code). Main component system abbreviations are "P" for PCM, "I" for IPC, "A" for ACP, "R" for SIR/DERM, "T" for TCS and "S" for RTD/RSS.

5) Trouble codes are displayed in system order. First PCM codes, followed by IPC, ACP, SIR, TCS and RTD codes. Write down all codes displayed, as another system's trouble codes could be related to specific IPC problem. See IPC TROUBLE CODES table.

6) The "C" after code number refers to a current trouble code, indicating that problem presently exists. The "H" after code number refers to a history trouble code, indicating problem has occurred in the past but is not now present.

7) After all trouble codes have been displayed, select individual system by pressing the LO button repeatedly until desired system is displayed, then pressing the HI button to lock in the desired system. Depressing OFF button will stop selection process and return to the beginning of trouble codes display sequence.

8) To exit self-diagnostics mode at any time, press AUTO button on CCC panel. Systems will return to normal operations. To continue self-diagnostics by selecting test type, see SERVICE MODE OPERATION.

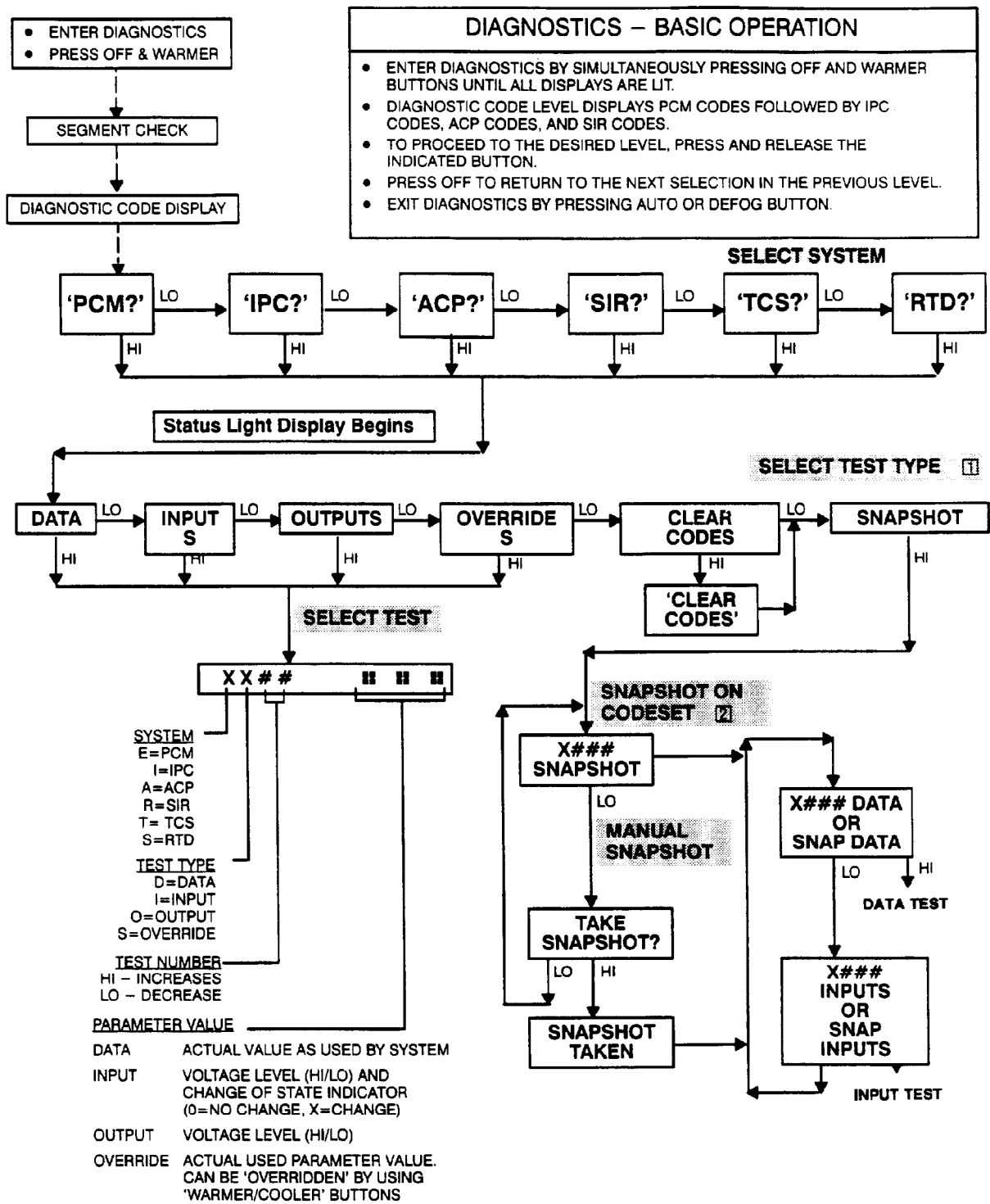

INSTRUMENT

a 92

① NOT ALL TEST TYPES WILL BE AVAILABLE FOR ALL SYSTEMS.

② SNAPSHOT ON CODESET MAY BE REPEATED FOR UP TO 3 CODES DEPENDING ON SYSTEM TESTED. IF NO CODES ARE STORED, SYSTEM WILL PRECEED DIRECTLY TO MANUAL SNAPSHOT.

93J41128

Fig. 6: Service Mode Operation Chart
 Courtesy of General Motors Corp.

IPC TROUBLE CODES TABLE

AA

Code	Test Condition
I022 (1) Panel Light Dimming Pot
I022 (1) Circuit Problem
I027 (2) PRND231 Failure
I032 (3) Loss Of ABS/TCS (4.6L)
I033 (3) Loss Of SIR Data
I034 (4) Loss Of PCM Data
I037 (5) Loss Of A/C Programmer (ACP) Data
I039 (3) Electronic Suspension System Problem
I041 (3) Battery Volts Too Low
I042 (3) Battery Volts Too High
I052 (6) IPC Memory Reset Indicator
I056 (7) IPC EEPROM Error

- (1) - This fault does not turn on any light or message.
- (2) - Displays "---" around each of the gear selections.
- (3) - Displays status message on DIC.
- (4) - Displays "---" in fuel data center, coolant temperature and RPM.
- (5) - Displays "---" in outside and set temperature displays.
- (6) - Switches Electronic Engine Control (EEC) mode to AUTO 75°F.
- (7) - Displays ERROR in season odometer.

AA

SELF-DIAGNOSTIC SYSTEM CHECK

NOTE: Use this check when IPC self-diagnostics cannot be entered, or IPC display stays blank.

1) Remove instrument panel top cover to access cluster connectors. See INSTRUMENT PANEL TOP COVER under REMOVAL & INSTALLATION. Using DVOM with negative probe connected to ground, backprobe IPC connector terminals No. A1, A2, C12, and C14 for 10 volts or more. See Fig. 3.

2) If all voltage readings are below specification, check/repair battery and charging system for fault, and retest IPC. If all voltage readings are within specification, go to step 4). If one or more voltage readings are not within specification, go to next step.

3) Trace particular wiring circuit to repair open or short. See WIRING DIAGRAMS. After repairs, retest IPC. If still unable to enter self-diagnostics mode, replace IPC. See INSTRUMENT PANEL CLUSTER under REMOVAL & INSTALLATION.

4) Turn ignition off. Disconnect IPC connectors. Measure

resistance to ground at terminals A5 and C16. See Fig. 3. If resistance reading for either terminal is greater than 2 ohms, repair open in that circuit. If resistance reading for both is less than 2 ohms, go to next step.

5) Reconnect IPC connectors. Turn ignition on. With voltmeter connected to ground, backprobe IPC connector terminal B2 (Yellow wire). If voltage reading is less than 14 volts, go to step 7). If voltage reading is 14 volts or greater, go to next step.

6) Inspect connectors and terminals for damage or bad terminal contacts of IPC. Repair as required. Reconnect connectors to IPC and retry to enter self-diagnostics mode. If still unable to enter self-diagnostics mode, replace IPC. See INSTRUMENT PANEL CLUSTER under REMOVAL & INSTALLATION.

7) Disconnect radio control head connector. Measure voltage at IPC connector terminal B2. If voltage reading is less than 14 volts, go to next step. If voltage is at least 14 volts, replace radio control head.

8) Disconnect Black IPC connector. Check for continuity to ground at IPC connector terminal B2 (Yellow wire). If continuity is present, repair short to ground in Yellow wire. If continuity is not present, replace IPC. See INSTRUMENT PANEL CLUSTER under REMOVAL & INSTALLATION.

SERVICE MODE OPERATION

NOTE: In Service Mode, the PCM, IPC, ACP, SIR, TCS and RTD systems can be tested. Only information related to IPC diagnosis and testing is given in this article.

After trouble codes have been displayed, service mode can be used to individually perform several tests for each trouble code displayed. Service mode can also clear all trouble codes and then exit diagnostics.

Selecting System

Following the trouble code display, first available system will be displayed. See Fig. 6. When selecting a system to test, any of the following actions may be taken to control the display:

- * Pressing LO button (fan down) on Climate Control Center (CCC) will display next available system selection. Available systems will display in following order: PCM?, IPC?, ACP?, SIR?, TCS?, RTD?.
- * Pressing HI button (fan up) on CCC will select and lock in system being displayed. When IPC? displays, press HI button. Next, proceed to SELECTING TEST TYPE.
- * Pressing AUTO button on CCC will exit self-diagnostics, and return display to normal CCC operation.

- * Pressing OFF button on CCC will stop system selection process and return display to beginning of trouble code display sequence.

Selecting Test Type

1) Having selected IPC? system by pressing HI button, the first available test type will be displayed (i.e., IPC DATA?). Test types include: IPC DATA?, IPC INPUTS?, IPC OUTPUTS?, IPC OVERRIDE?, IPC CLEAR CODES? or IPC SNAPSHOT?. If selecting clear codes or snapshot, see IPC CLEAR CODES or IPC SNAPSHOT under SELF-DIAGNOSTICS.

2) The first 4 characters in display will identify test code that has been selected. First 2 characters of test code identify system and test type selected (i.e., ID50="I" for IPC system, "D" for Data test type). The last 2 numerical characters of test code identify the specific test selected. For example, ID50 is DATA parameter for Battery Volts. See IPC SPECIFIC DATA CODES. See Fig. 6.

3) While selecting a specific test type, any of following actions may be taken to control display:

- * Pressing HI button (fan up) on Climate Control Center (CCC) will select displayed test type. At this point the first of several specific tests will appear.
- * Pressing LO button (fan down) on CCC will display next available test type for the same selected system. This button allows display to be stepped through all available test type choices for same selected system. Test types will be repeated following the display of last test type.
- * Pressing OFF button on CCC will stop test type selection process and return display to next available system selection.
- * Pressing AUTO button on CCC will halt diagnostics and system will return to normal display and operation.

Selecting Specific Test

1) After selection of test type (such as IPC DATA?), the first available test code parameter will display. See IPC SPECIFIC DIAGNOSTIC CODE PARAMETER DESCRIPTIONS and see IPC TROUBLE CODES table.

2) If dashes (- - -) appear in CCC display, this indicates that selected specific test is not valid, not applicable or test conditions are wrong. While selecting a specific test, following actions may be taken to control display:

- * Pressing HI button (fan up) on CCC will display the next highest specific test number in selected test type. If HI button is pressed when highest test number is being displayed, display will return to lowest test number.
- * Pressing LO button (fan down) on CCC will display the next lowest specific test number in selected test type.

smaller test number in selected test type. If LO button is pressed when lowest test number is being displayed, display will return to highest test number.

- * Pressing OFF button on CCC will stop test selection process and return display to next available test type for selected system.
- * Pressing AUTO button on CCC will halt diagnostics and return system to normal display and operation.

IPC SPECIFIC DIAGNOSTIC CODE PARAMETER DESCRIPTIONS

Data Code Values

The value displayed is the actual analog value that is seen and used by system.

Input Codes

Input tests will display on or off status of selected device as "HI" or "LO". Display will also indicate if input changed status so technician can activate or deactivate device and then return to display parameter to see if device changed status. If a status change occurred, "X" will appear next to HI/LO indicator, otherwise "O" will remain displayed.

"X" will appear only once per selected input test even if HI/LO changes occur as input values change. Constant displaying "X" after a test detects input test changes that are only momentary and could not be seen otherwise.

Override Test Codes

IPC override feature allows testing of certain system functions regardless of normal program instructions, provided test conditions are met.

When an override test is selected, current mode of the function will be displayed as a percentage on Climate Control Center (CCC) panel. If test conditions are not met, CCC panel will display "--" in place of override value selected. This display will alternate between "--" and normal program value whenever an override value is not commanded.

After selecting an override value, press WARM button to increase override value, or press COOL button to decrease override value. Upon release of either button, display may either remain at override value or automatically return to normal program control, depending on which item or function is being overridden at that time.

Selection of another override test or selection of another system will cancel current override test. See Fig. 6. Overriding value beyond one extreme will display "--" momentarily, then display will jump to opposite extreme. If button is released while "--" is displayed, normal program control will resume and display will begin alternating again.

IPC CLEAR CODES

1) To clear all IPC codes, select IPC CLEAR CODES? option under test type by pressing "HI" button on CCC panel. Message IPC CODES CLEAR will display. Message will appear for 3 seconds, indicating all stored trouble codes have been erased from memory for selected system (IPC).

2) After 3 seconds, display will automatically return to next available test type for selected system. After a code(s) has been cleared, a complete ignition cycle and possible test drive should be made. Recheck for trouble code(s) to ensure that code does not reset.

IPC SNAPSHOT

IPC SNAPSHOT? mode gives technician the ability to view individual IPC code parameter values. Parameter values to be displayed are those of DATA? or INPUT? tests that were stored in IPC keep alive memory when code was set or at a particular instant of time as chosen by technician. If more than one code sets, only snapshot values associated with the last code will be stored.

Selecting IPC Code-Set Snapshot

To use snapshot, enter diagnostics and press "LO" button until IPC SNAPSHOT? is displayed. Press "HI" to enter snapshot mode. Display should read IXXX SNAPSHOT (IXXX being IPC trouble code number). If this number is not desired trouble code, press "LO" button to go to next stored trouble code. Repeat as needed. If display reads TAKE SNAPSHOT?, press "LO" again until desired stored trouble code appears. When desired code appears, press "HI" to display IXXX DATA? XXX. Parameter value numbers (XXX) following IXXX DATA? is desired snapshot data. If a more recent snapshot of displayed trouble code is desired, see MANUALLY SELECTING IPC SNAPSHOT?.

Manually Selecting IPC SNAPSHOT?

If no code-set snapshot information is available or stored trouble codes are by-passed until TAKE SNAPSHOT? is displayed, a manually-triggered snapshot may be taken. Operate vehicle until intermittent condition occurs or until desired conditions are met to be viewed and recorded by technician. When TAKE SNAPSHOT? is displayed, press "HI" on CCC panel. Display will read SNAPSHOT TAKEN and then change to SNAP DATA. This indicates data is now stored for review. This selection will store one set each of IPC DATA and IPC INPUT parameter values at moment snapshot was taken. This process will help to diagnose intermittent problems. To view information, see VIEWING SNAP DATA? OR IXXX DATA? DISPLAY.

1) Pressing HI button will select DATA values taken during snapshot. Pressing LO button will select INPUT values taken during snapshot.

2) To view code values selected, press "HI" or "LO" to increase or decrease code numbers. Press OFF button once to return to original snapshot display or twice to return to next available test selection. To exit self-diagnostics, press AUTO button or turn ignition off. Trouble codes are not erased when this is done.

NOTE: Only IPC specific DATA and INPUT codes are listed in this article. For PCM codes, see appropriate G - TESTS W/CODES article in the ENGINE PERFORMANCE section.

G - TESTS W/CODES - 4.6L - Concours

G - TESTS W/CODES - 4.9L - DeVille

IPC SPECIFIC DATA CODES

ID40

FUEL LEVEL is read from fuel sender unit in gallons between 0.0 and 24.7.

ID42

DIMMING POT PWM is read as a Pulse Width Modulation (PWM) between 0 and 100 percent. Typical range of 24 (max dim) to 95 (full bright). ID42 only updates while parking lights or headlights are on.

ID50

BATTERY VOLTS is read in voltage between 0.0 and 18.0, at pin C13 of IPC White connector (Ignition 1 voltage reading).

ID60

VEHICLE SPEED is read in MPH between 0 and 255.

ID80

LOW BRAKE FLUID signal is read in volts between 0 and 5.

ID89

OPTION 0 is the decimal equivalent of an 8-bit binary code specifying vehicle option content. For complete details, see IS07 under IPC SPECIFIC OVERRIDE DISPLAYS.

ID90

OPTION 1 is the decimal equivalent of an 8-bit binary code specifying vehicle option content. The value is set between 0 and 255. For complete details, see IS08 under IPC SPECIFIC OVERRIDE DISPLAYS.

ID91

OPTION 2 is the decimal equivalent of an 8-bit binary code specifying vehicle option content. The value is set between 0 and 255. For complete details, see IS09 under IPC SPECIFIC OVERRIDE DISPLAYS.

ID97

IGNITION CYCLE COUNTER value is the number of times that the IPC has been turned OFF since IPC trouble code was last detected. After 100 ignition cycles without any further malfunction being detected, all IPC codes are cleared.

ID98

IDC SOFTWARE VERSION indicates software identification number for one of IPC microprocessors.

ID99

VSM SOFTWARE VERSION indicates software identification number for second IPC microprocessor.

IPC SPECIFIC INPUT CODES

II07

TRUNK SWITCH display reads "HI" with trunk closed.

II09

WASHER FLUID LEVEL SWITCH displays "LO" when vehicle is low on washer fluid.

II10

GENERATOR FEEDBACK display is "LO" when there is a generator (alternator) problem or engine is not running.

II11

METAL TEMPERATURE switch input reads "LO" when metal temperature switch is closed ("hot" engine condition).

II12

RIDE CONTROL FAULT display reads state of CCR input. Normal operation is "LO" below 5 MPH and "HI" above 15 MPH.

II65

OIL PRESSURE SWITCH will indicate "HI" with proper oil pressure.

II67

PARK input which is used to display APPLY BRAKE TO SHIFT indication (4.6L).

LEFT TURN SWITCH will indicate "LO" with left turn signal not selected, and toggle "LO/HI" while directional is active.

II91

RIGHT TURN SWITCH will indicate "LO" with right turn signal not selected and toggle "LO/HI" while directional is active.

II93

HIGH BEAM SWITCH will indicate "HI" with high beams on.

II94

PARK LIGHT INPUT will read "HI" with parking lights or headlights on.

IPC SPECIFIC OVERRIDE DISPLAYS

IS00

The display will read NONE, meaning no overrides are active at this point.

IS07

OPTION 0 override allows the ability to change vehicle option content information stored in IPC. IPC uses this option information to determine how to operate displays and other electronic devices. Incorrect option content information in IPC may cause many different problems. Upon selection of this override option content information will be displayed as a number. To determine proper OPTION 0 number, calculate sum of applicable numbers from IPC OVERRIDE IS07 OPTION 2 CONTENT VALUE SPECIFICATIONS table.

IPC OVERRIDE IS07 OPTION 2 CONTENT VALUE SPECIFICATIONS TABLE

AA

Application Value

Options (Add Values Together)

Tinted Glass	16
DeVille & Concours	0
Option Not Set	64
Suppress Low Engine Oil	128

Normal Option IS07 Values

With Tinted Glass	16
Without Tinted Glass	0

AA

IS08

OPTION 1 override allows the ability to change vehicle option content information that is stored in IPC memory. The IPC uses this information to determine how to operate displays and other electronic devices.

devices. Incorrect option content information in IPC causes many different problems.

Upon selection of override, the option content information number will be displayed. To determine the proper OPTION 1 number, determine if vehicle is equipped with either of the following, and then add or subtract the number amount using the WARMER (increase) or COOLER (decrease) buttons.

If vehicle has French Canadian displays, add 128. If vehicle has Ride Control, add 8. If vehicle is not equipped with one or both of these options, subtract the amount from OPTION 1 number. When correct number is reached, simultaneously press and hold ECON and FRONT DEFROST buttons for 3 seconds to permanently store NEW correct value in EEPROM. Display will blank momentarily and then display new number.

IS09

OPTION 2 override allows the ability to change another set of vehicle options stored in IPC memory. IPC uses this information to determine how to operate displays and other electronic devices. Incorrect option content information in IPC causes many different problems.

Upon selection of override the option content information number will be displayed. To determine the proper OPTION 2 number, determine which options vehicle is equipped with, and then add or subtract the number amount using the WARMER (increase) or COOLER (decrease) buttons. See IPC OVERRIDE IS09 OPTION 2 CONTENT VALUE SPECIFICATIONS table.

IPC OVERRIDE IS09 OPTION 2 CONTENT VALUE SPECIFICATIONS TABLE

AA

Application Value

Options (Add Values Together)

Heated Windshield	128
Traction Control	64
Analog Cluster Mode	32
Fuel Tank (All Models)	16
Permit REDUCED ENGINE POWER	8
Brake Fluid Sensor (4.6L)	4
Suppress COOLANT LEVEL Message (4.9L)	2
Permit APPLY BRAKE TO SHIFT Message	1

Normal Option IS09 Values

4.6L	
With Heated Windshield	245
Without Heated Windshield	117
4.9L	
Analog IPC	
With Heated Windshield	179

Without Heated Windshield	51
Digital IPC	
With Heated Windshield	147
Without Heated Windshield	19

AA

When correct number is reached, simultaneously press and hold ECON and FRONT DEFROST buttons for 3 seconds to permanently store NEW correct value in EEPROM. The display will blank momentarily and then display the new number.

IS10

SET TEMP OFFSET is used to allow the set temperature to be up to 5 degrees different from the commanded set temperature. This could be used if customer complaint is that system is too warm, SET TEMP OFFSET should be changed negative 5 degrees, and vice versa if complaint is that system is too cold.

IS11

OPTION 3 override allows ability to change vehicle option content information stored in IPC. IPC uses this option to store vehicle body type. IPC communicates this information to SDM over serial data so SDM can determine if it is installed in correct vehicle. If SDM calibration and IPC body type do not match, a calibration error is detected and SDM sets a SIR Code R055. Incorrect OPTION 3 content information will cause SDM to set SIR code R055. Upon selection of this override, option content information will be displayed as a number. To determine proper OPTION 3 number, see OPTION 3 NUMBER table.

OPTION 3 NUMBER TABLE

AA

Body Type	Number
Concours, DeVille	4

AA

IS45

VACUUM FLUORESCENT DIMMING override will control IPC and radio VF displays from "0" (MAX dim) to "99" (MAX bright). Display will hold override value upon release of buttons.

IPC MALFUNCTION SYMPTOMS

NOTE: Following are signs and indications that a trouble code or IPC problem exists.

Two Hyphens "--" Displayed In Set Temp INSTRUMENT PANEL/

This indicates a failure has occurred in serial communication line between IPC and ACP. Codes I037 and/or A037 will be set.

Two Hyphens "--" Displayed In Outside Temp

This indicates outside temperature sensor or serial communication line between IPC and ACP has failed. Codes A010, I037 and/or A037 will be set.

Two Hyphens "--" Displayed In Fuel Data Panel

This indicates a failure has occurred in serial communication line between IPC and PCM. Code I034 will be set and others could be set.

Two Hyphens "--" Displayed In RPM Or Coolant Temp. Gauges

On vehicles equipped with digital clusters, this indicates a failure has occurred in serial communication line between IPC and PCM. Code I034 will be set.

DIC Displays Numbers With Driver Messages

In some cases a number will be displayed with a driver information message, such as 24 TRUNK OPEN. This indicates IPC is configured for a country that does not use English as primary language. Number indicates cross reference in Non-English owner's manual. To change configuration, refer to IPC diagnostic parameters such as IS08 and IS09 (IPC EEPROM Option Content). See IPC SPECIFIC OVERRIDE DISPLAYS.

Speed Display Higher Than Actual Speed

Ensure tire size is as specified for vehicle. Also, if EEPROM option register No. 1 is set for European Economic Community, speedometer will read about 7 percent higher than actual speed. To change configuration, refer to IPC diagnostic parameters such as IS08 and IS09 (IPC EEPROM Option Content). See IPC SPECIFIC OVERRIDE DISPLAYS.

Speed Flashes At 180 KPH

When EEPROM option register No. 1 is set for Japanese, speedometer will not display greater than 180 KPH. At speeds greater than 180 KPH, display will flash 180. To change configuration, refer to IPC diagnostic parameters such as IS08 and IS09 (IPC EEPROM Option Content). See IPC SPECIFIC OVERRIDE DISPLAYS.

Speed Flashes At 120 KPH

When EEPROM option register No. 1 is set for Saudi Arabia, speedometer will not display greater than 120 KPH. At speeds greater than 120 KPH, display will flash while indicating actual speed. To change configuration, refer to IPC diagnostic parameters such as IS08 and IS09 (IPC EEPROM Option Content). See IPC SPECIFIC OVERRIDE DISPLAYS.

DISPLAYS.

Trip Odometer Resets At 1242.6 Miles (1999 Kilometers)

When EEPROM option register No. 1 is set for any other country other than U.S., odometer will reset at 1242.6 miles or 1999 kilometers. This will happen regardless of English/Metric mode. To change configuration, refer to IPC diagnostic parameters such as IS08 and IS09 (IPC EEPROM Option Content). See IPC SPECIFIC OVERRIDE DISPLAYS.

Fuel Type Logo Inoperative

When EEPROM option register No. 2 is set for a leaded fuel vehicle, "Unleaded Premium Fuel Only" logo will not normally display. To change configuration, refer to IPC diagnostic parameters such as IS08 and IS09 (IPC EEPROM Option Content). See IPC SPECIFIC OVERRIDE DISPLAYS.

No Low Fuel Warning

When EEPROM No. 2 is set to suppress low fuel warnings, FUEL LEVEL VERY LOW warning message will not display. On digital IPC equipped vehicles, fuel gauge will display "E" when fuel level is low. To change configuration, refer to IPC diagnostic parameters such as IS08 and IS09 (IPC EEPROM Option Content). See IPC SPECIFIC OVERRIDE DISPLAYS.

DIC MESSAGES

FUEL LEVEL VERY LOW Message Or CHECK FUEL GAUGE Message

1) Fuel level signal is measured only in whole gallons (or liters), no tenths, so fuel level displayed is rounded off to nearest whole number. When IPC reads fuel level as 1.0 gallon, the "E" will flash and the message FUEL LEVEL VERY LOW will display on DIC.

2) If display is operating in DISPLAY OFF mode and fuel level falls to less than 4 gallons, all displays will illuminate and become active again. DIC will then display CHECK FUEL GAUGE.

3) If these conditions were met and these messages did not appear, check for ignition voltage at IPC connector terminal C13 using DVOM. See Fig. 3. If voltage is good, check fuel gauge and sending unit. See IPC MALFUNCTION SYMPTOMS under SELF-DIAGNOSTICS and FUEL GAUGE INOPERATIVE/INACCURATE under IPC TESTS under COMPONENT TESTING.

CHECK WASHER FLUID Message

1) When washer fluid level switch closes for more than 15 seconds, it pulls IPC washer fluid input circuit down to low voltage. IPC detects this condition at IPC terminal D13 and displays message on DIC.

2) If washer fluid is empty and message did not display, check for ignition voltage at IPC connector terminal C13 using INSTRUMENT PAN

See Fig. 3. If voltage is good, check for open in sensor or open in Black/White wire between IPC connector terminal D13 and washer sensor and between sensor and ground.

3) If message displays with full washer fluid container, check for short to ground in Black/White wire circuit between IPC connector terminal D13 and washer sensor, and between sensor and ground.

STOP ENGINE - ENGINE OVERHEATED Message

1) When engine metal temperature switch closes for more than 2 seconds, IPC will detect low voltage at IPC terminal D10 and display message and sound chime. If engine overheated and no message displayed, check for open in Light Green wire circuit between IPC terminal D10 and metal temperature switch, metal temperature sensor, and Black wire ground circuit from sensor. See Fig. 3.

2) If message displays with cold engine, check for short to ground in Light Green wire circuit between IPC terminal D10 and sensor, or shorted sensor.

ENGINE COOLANT HOT - IDLE ENGINE Message

1) When engine coolant temperature reaches 285°F (140°C), PCM reports to IPC to display message. Message will continue to be displayed until temperature falls to less than 275°F (135°C).

2) The message cannot be displayed if IPC loses communication with PCM (such as Code I034), or if PCM sees a coolant sensor failure (such as Codes P014/P015). If engine overheated and no message displayed, check for these trouble codes and check for defective coolant sensor.

SET TIMING MODE Message (4.9L)

1) Set timing mode is designed to allow technician to disable spark advance when diagnosing ignition and fuel control problems. If message is displayed, PCM has sensed a ground in Pink/Black wire circuit and indicated IPC to display message.

2) If message is displayed, ensure Data Link Connector (DLC) pin "B" is not grounded while engine is running, and/or ensure a ground does not exist in Pink/Black wire circuit between DLC and PCM connector C3 terminal E12. See Fig. 4 or 5. Engine will operate at base engine timing as long as message is displayed.

TRUNK OPEN Message

1) IPC provides voltage to trunk pull-down switch to monitor if trunk is open. Trunk pull-down switch provides ground path for voltage signal. If message is displayed and trunk is closed, check for ground in Black/Orange wire circuit between trunk pull-down switch and IPC connector terminal D7. See Fig. 3.

2) If no ground exists, replace grounded trunk switch. If trunk is open with engine running and no message is displayed, check INSTRUMENT

for open in Black/Orange wire, trunk switch, and/or Black ground wire of switch.

BATTERY NO CHARGE Message (4.9L)

1) IPC will display this message if system voltage input to IPC terminal D12 is low for more than 2 seconds. See Fig. 3. If alternator output is low, terminal "L" of alternator regulator will ground internally and IPC will sense voltage drop and display message. Disconnect alternator connector.

2) Turn ignition on (engine off). Check for system voltage (12V) at terminal "L" of alternator connector. If voltage does not exist, check for open or short in Red wire circuit between IPC connector terminal D12 and alternator connector. Repair as required.

LOW OIL PRESSURE - STOP ENGINE Message

1) This message displays when oil pressure switch is closed for more than 2 seconds when engine is running. PCM communicates to IPC that engine is running. If this communication line is lost, a Code I034 will be set. If Code I034 is set when ignition is on and engine is off, IPC will assume engine is running and display message on DIC.

2) If Code I034 is not set, and message is displayed when oil pressure is known to be greater than 5 psi at idle, check for short to ground in Tan wire circuit between IPC connector terminal D5 and oil pressure switch. See Fig. 3. Also check for shorted pressure switch.

3) If oil pressure is known to be less than 3 psi at engine idle and message does not display, check for open in Tan wire circuit or in Black ground wire circuit from switch.

CHANGE OIL SOON Or CHANGE ENGINE OIL Message

1) When oil life index reaches 10 percent or mileage since the last oil change reaches 6750, the CHANGE OIL SOON message will be displayed. When oil life index reaches zero percent, the CHANGE ENGINE OIL message will be displayed.

2) To reset oil life index, press INFORMATION button until oil life index is displayed. Press and hold STORE/RECALL button for approximately 5 seconds until oil life index is reset to 100.

APPLY BRAKE TO SHIFT Message

1) A shift interlock system prevents shifting out of Park position unless service brake is depressed. PCM monitors brake switch and sends this information to IPC. Transmission position switch sends gear position data either directly to IPC (4.6L) or to PCM (4.9L) which then transfers it to IPC.

2) Message will be displayed if ignition is on for at least 5 seconds, transmission is in Park position and brake pedal is not pressed. If message is not being displayed properly, check for correct message enable status. See IS09 of IPC SPECIFIC OVERRIDE DISPLAYS under SELF-DIAGNOSTICS.

CHECK BRAKE FLUID Message & BRAKE Warning Light

1) When brake fluid level switch detects a low condition for at least 3 seconds with ignition on, CHECK BRAKE FLUID message should be displayed and BRAKE warning light should come on.

2) If brake fluid level is okay and message is displayed and warning light comes on, check for short to ground in Red wire between IPC and low brake fluid level switch. Also check for shorted switch.

TROUBLE CODES

Code I022 - Panel Dimming Switch Pot Circuit

1) Turn ignition switch and headlight switch on. Enter self-diagnostics. See ENTERING SELF-DIAGNOSTICS under SELF-DIAGNOSTICS. Monitor ID42 dimming input. If display value is "4" or less, go to step 3). If display value is "5" or more, no problem is found. Go to next step.

2) If no problem is found, check for an intermittent problem by turning dimmer switch through its full travel, watching for sudden jumps in display numbers. If a failure is induced, display reading will jump from normal value to a value less than "4". Remove headlight switch and instrument panel top cover. Ensure good terminal contacts at headlight switch connector and at IPC connector cavities D3 and C10. See Fig. 3. Wiggle test related wiring while observing IPC Data value ID42.

3) Turn headlights on. Using voltmeter, connect one lead to ground and backprobe headlight switch 4-cavity connector terminal "C" (Gray wire). Rotate dimmer switch. If voltage changes with dimmer switch movement, go to step 6). If voltage does not change or is not present, go to next step.

4) Leave headlights on. Using both DVOM probes, backprobe between headlight switch 4-cavity connector terminals "B" (Brown wire) and "A" (Black wire). If voltage is less than 8 volts, go to next step. If voltage is 8 volts or more, check for faulty connections at headlight switch 4-cavity connector. If all connections are good, replace headlight switch.

5) Leave headlights on. Using DVOM, backprobe headlight switch 4-cavity connector terminal "B" (Brown wire) to ground. If voltage is less than 8 volts, repair open in Brown wire between headlight switch and IPC. If voltage is 8 volts or more, repair open in Black wire from headlight switch to ground.

6) Using DVOM, backprobe IPC connector terminal C10 to ground. See Fig. 3. Rotate dimmer switch. If no voltage exists, repair open in Gray wire circuit between headlight switch and IPC.

7) If voltage changes with dimmer switch, check IPC connector terminals for faulty terminals/connections. If connections are good, replace IPC. See INSTRUMENT PANEL CLUSTER under REMOVAL & INSTALLATION. After all

verify correct operation.

Code I027 - PRND321 Sensor Failure

1) Park/Neutral position switch is mounted on transaxle assembly. There are 2 parts to this diagnostic code definition. The first part results in electronic PRND321 illuminating all display segments around each of the gear selections. If ignition switch is in either UNLOCK or RUN position, Code I034 (Loss Of PCM Data) is not currently set, PRND321 state as decoded by IPC indicates Park or Neutral and PCM does not indicate Park or Neutral, or vice versa, and this remains true for .6 second, then PRND321 display illuminates all display segments around each of the gear selections. If this condition continues for 3 seconds or more, then Code I027 sets current.

2) If PCM Code P091 is also set, see the appropriate G - TESTS W/CODES article in the ENGINE PERFORMANCE section. If PCM Code P091 is not set, go to next step.

G - TESTS W/CODES - 4.6L - Concours

G - TESTS W/CODES - 4.9L - DeVille

3) Turn ignition on. Shift transmission into Park. Using ID41 parameter, read PRND321 display. If ID41 display matches GEAR SELECTOR POSITION table for Park position, go to next step. If display does not match GEAR SELECTOR POSITION table, go to step 5).

GEAR SELECTOR POSITION TABLE

```

AAAAAAAAAAAAAAAAAAAAAAAAAAAAAAAAAAAAAAAAAAAAAAAAAAAAAAAAAAAAAAAAAAAA
Gear Position                ID41 Display          ID41 Display
                             A/B                    C/P

Park (P) ..... LO/HI ..... HI/LO
Reverse (R) ..... LO/LO ..... HI/HI
Neutral (N) ..... HI/LO ..... HI/LO
Drive (D) ..... HI/LO ..... LO/HI
Drive 3 (3) ..... LO/LO ..... LO/LO
Drive 2 (2) ..... LO/HI ..... LO/HI
Drive 1 (1) ..... HI/HI ..... LO/LO
AAAAAAAAAAAAAAAAAAAAAAAAAAAAAAAAAAAAAAAAAAAAAAAAAAAAAAAAAAAAAAAAAAAA

```

4) Compare ID41 display in each gear selection position to GEAR SELECTOR POSITION table. If ID41 display matches table for all combinations, replace IPC. If ID41 display does not match table for all combinations, check wiring for an open or short circuit to ground.

5) If ID41 does not display high for all inputs, go to next step. If ID41 displays high for all inputs, check Black/White wiring for an open circuit. Check all in-line connectors for good terminal contact. Check Park/Neutral position switch for correct operation. If all checks are okay, replace IPC.

6) If ID41 does not display high or low for all inputs, move gear selector lever from Park to Drive. Repair wiring associated with input that does not change. Repeat system check.

7) If ID41 displays high for all inputs, turn ignition off. Disconnect connector at Park/Neutral switch Black/White wire. Turn ignition on. If ID41 now displays high for all inputs, replace Park/Neutral switch. Repeat system check. If ID41 does not display high for all inputs, check all PRND321 circuits for a short to ground. If all circuits are okay, replace IPC.

NOTE: Following test should be used when multiple codes exist.

Multiple Data Communication Codes (4.6L)

1) Ensure Data Link Connector (DLC) cover is properly seated to DLC. If it is, go to step 3). If it is not, clear all codes, install DLC cover properly and test drive vehicle for more than 10 miles. Enter self-diagnostics and recheck for trouble codes. See ENTERING SELF-DIAGNOSTICS under SELF-DIAGNOSTICS.

2) DLC cover contains a serial data line jumper connection. When DLC cover is in place, this jumper connects DLC terminals "M" and "L" to complete the serial data line communication link between all computer systems.

3) Ensure DLC cover is properly positioned. Enter self-diagnostics and record all trouble codes. See ENTERING SELF-DIAGNOSTICS under SELF-DIAGNOSTICS. If both Codes I033 and I037 are set, repair open in Tan wire between DERM and IPC or between ACP and PCM. Diagnostic Energy Reserve Module (DERM) is located directly above brake pedal. DERM has Yellow connector and wiring harness. A/C Programmer (ACP) is located left of PCM, behind glove box. If both Codes I034 and I037 are set, repair open in Tan wire between IPC and PCM or between ACP and DERM. See WIRING DIAGRAMS.

4) If both Codes I034 and E052 are set, PCM has lost power. Diagnose as per PCM Code P052. See the G - TESTS W/CODES - 4.6L article in the ENGINE PERFORMANCE section. If Codes I032 or I032 and I034 are set, diagnose as per IPC Code I032. If both Codes I034 and E047 are set, IPC has lost communications with PCM. Diagnose as per IPC Code I034. If both Codes I037 and A037 are set, IPC has lost communications with ACP. Diagnose as per IPC Code I037.

5) If Codes A037, P047 and T072 are set (I052 may also be set), there is serial data line communication link break down. Diagnose as per IPC Code I052. If Codes I039 and T072 are set, there is a loss of Road Sensing Suspension (RSS) data. Diagnose as per IPC Code I039.

6) If Codes I032, I033, I034 and I037 are all set, and these are current ("C") codes, go to next step. If these are history ("H") codes, check the following and repair as needed:

* Check for poor connections. INSTRUMENT PANEL Article Text (p. 33) 1995 Cadillac Concour

See Fig. 3.

- * Check for intermittent short to ground or short to battery voltage anywhere in Tan wire circuit.
- * Check for intermittent open in Tan wire circuit between IPC and DERM and between IPC and PCM.
- * Check each computer component along Tan wire circuit to be holding serial data line at a constant voltage.

7) Disconnect PCM connector C2. See Fig. 4. PCM is located on right kick panel. Remove DLC cover. Using DVOM, measure voltage at DLC terminal "M". If voltage does not fluctuate between 3 and 5 volts, go to step 14). If voltage fluctuates between 3 and 5 volts, disconnect ACP connector and reconnect PCM connector C2. ACP is left of PCM. Using DVOM, measure voltage at DLC terminal "M".

8) If voltage is fluctuating between 3 and 5 volts, go to step 10). If voltage is not fluctuating between 3 and 5 volts, disconnect PCM connectors. Using jumper wire, connect PCM harness connector C2, terminals 2C12 and 2C13. See Fig. 4.

9) Using DVOM, measure voltage at DLC terminal "M". If voltage is fluctuating between 3 and 5 volts, check PCM MEM-CAL for good connection into PCM, and check PCM connectors for good connections. If no connection problems exist, replace PCM. If voltage is not fluctuating between 3 and 5 volts at terminal "M", repair short in Tan wire circuit between ACP and PCM.

10) Disconnect Road Sensing Suspension (RSS) module mounted on board in electronics bay on right side of trunk. Reconnect ACP. Using DVOM, measure voltage at DLC terminal "M". If voltage is fluctuating between 3 and 5 volts, go to step 12). If voltage is not fluctuating between 3 and 5 volts, go to next step.

11) Disconnect ACP. Connect a jumper wire between ACP connector terminals C10 and C11. See Fig. 7. Using DVOM, measure voltage at DLC terminal "M". If voltage is fluctuating between 3 and 5 volts, repair short in Tan wire between ACP and RSS module. If voltage is not fluctuating between 3 and 5 volts, ensure proper MEM-CAL insertion in ACP and proper terminal contact at ACP. If no problems are found, replace ACP.

12) Connect a jumper wire between RSS C2 (Green) connector terminals D8 and D9. See Fig. 11. Using DVOM, measure voltage at DLC terminal "M". If voltage is not fluctuating between 3 and 5 volts, go to next step. If voltage is fluctuating between 3 and 5 volts, check for proper terminal contact at RSS connector. If terminal contact is okay, replace RSS module.

13) Disconnect Electronic Brake Control Module (EBCM) connector. EBCM is mounted to center of cross brace behind rear seat and is accessible from trunk. Using DVOM, measure voltage at DLC terminal "M". If voltage fluctuates between 3 and 5 volts, replace EBCM. If voltage does not fluctuate between 3 and 5 volts, repair short in Tan wire between ACP and DLC terminal "L".

14) Ensure PCM connector and DLC cover are still disconnected. Disconnect Yellow DERM connector. DERM is mounted behind instrument panel above brake pedal. Using DVOM, measure voltage at DERM harness connector terminal A11. See Fig. 8. If voltage is not fluctuating between 3 and 5 volts, go to step 16). If voltage is fluctuating between 3 and 5 volts, use jumper wire to connect DERM harness connector terminals A11 and B11. Measure voltage at DLC terminal "M".

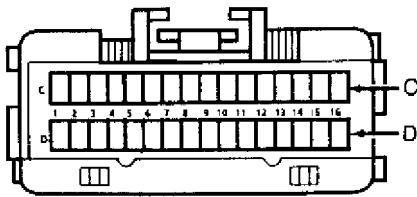

WHITE CONNECTOR

Fig. 7: Identifying ACP Connector Terminals
Courtesy of General Motors Corp.

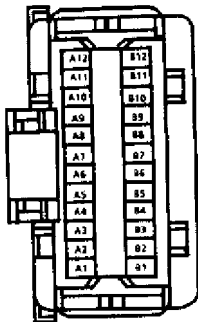

YELLOW CONNECTOR

Fig. 8: Identifying DERM Connector Terminals
Courtesy of General Motors Corp.

15) If voltage fluctuates between 3 and 5 volts at DLC terminal "M", check connections at DERM terminals. If connections are good, replace DERM. If voltage does not fluctuate between 3 and 5 volts at DLC terminal "M", repair short in Tan wire circuit between DERM and DLC terminal "M". See WIRING DIAGRAMS.

16) Turn ignition off. Disconnect IPC connectors. Leave DERM disconnected. Using DVOM, measure resistance to ground from IPC harness connector terminal C1. See Fig. 3. If resistance is 2000 ohms or less, repair short in Tan wire circuit between DERM and IPC. See WIRING DIAGRAMS.

17) If resistance is greater than 2000 ohms, connect jumper wire from DERM harness connector terminal A11 to ground. Measure resistance to ground from IPC harness connector terminal C1. If resistance is more than 2000 ohms, repair open in Tan wire circuit between IPC and DERM.

18) If resistance is 2000 ohms or less, ensure PCM is still disconnected. Measure resistance from ground to IPC harness connector

terminal C2. If resistance is more than 2000 ohms and terminal connections are good at IPC connectors, replace IPC. See INSTRUMENT PANEL CLUSTER under REMOVAL & INSTALLATION.

19) If resistance is now 2000 ohms or less, repair short in Tan wire circuit between IPC and PCM. After all repairs are completed, clear all codes and verify correct operation.

Multiple Data Communication Codes (4.9L)

1) Ensure DLC cover is properly seated to DLC connector. If it is, go to step 3). If it is not, clear all codes, install DLC cover properly and test drive vehicle for more than 10 miles. Enter self-diagnostics and recheck for trouble codes. See ENTERING SELF-DIAGNOSTICS under SELF-DIAGNOSTICS.

2) DLC cover contains a serial data line jumper connection. When DLC cover is in place, jumper connects DLC terminals "M" and "L" to complete the serial data line communication link between all computer systems.

3) Ensure DLC cover is properly positioned. Enter self-diagnostics and record all trouble codes. See ENTERING SELF-DIAGNOSTICS under SELF-DIAGNOSTICS. If both Codes I033 and I037 are set, repair open in Tan wire between DERM to IPC or between ACP to PCM. Diagnostic Energy Reserve Module (DERM) is located directly above brake pedal. DERM has Yellow connector and wiring harness. A/C Programmer (ACP) is located left of PCM, behind glove box. If both Codes I034 and I037 are set, repair open in Tan wire between IPC and PCM or between ACP and DERM. See WIRING DIAGRAMS.

4) If both Codes I034 and E052 are set, PCM has lost power. Diagnose as per PCM Code E052. See the G - TESTS W/CODES - 4.9L article in ENGINE PERFORMANCE. If both Codes I034 and E047 are set, IPC has lost communications with PCM. Diagnose as per IPC Code I034. If both Codes I037 and A037 are set, IPC has lost communications with ACP. Diagnose as per IPC Code I037.

5) If Codes A037 and E047 are set (I052 may also be set), there is serial data line communication link break down. Diagnose as per IPC Code I052. If Codes I033, I034 and I037 are all set, and these are current ("C") codes, go to next step. If these are history ("H") codes, check the following and repair as needed:

- * Check for poor connections at IPC terminals C1 and C2. See Fig. 3.
- * Check for intermittent short to ground or short to battery voltage anywhere in Tan wire circuit.
- * Check for intermittent open in Tan wire circuit between IPC and DERM, and between IPC and PCM.
- * Check each computer component along Tan wire circuit to be holding serial data line at a constant voltage.

6) Disconnect PCM connector C2. See Fig. 5. PCM is located on INSTRUMENT

right kick panel. Remove DLC cover. Using DVOM, measure voltage at DLC terminal "M". If voltage does not fluctuate between 3 and 5 volts, go to step 11). If voltage fluctuates between 3 and 5 volts, disconnect ACP connector and reconnect PCM connector C2. ACP is located left of PCM. Using DVOM, measure voltage at DLC terminal "M".

7) If voltage is fluctuating between 3 and 5 volts, go to step 9). If voltage is not fluctuating between 3 and 5 volts, disconnect PCM connectors. Using jumper wire, connect PCM harness connector C2, terminals A8 and A9. See Fig. 5.

8) Using DVOM, measure voltage at DLC terminal "M". If voltage is fluctuating between 3 and 5 volts, check PCM MEM-CAL for good connection into PCM, and check PCM connectors for good connections. If no connection problems exist, replace PCM. If voltage is not fluctuating between 3 and 5 volts at terminal "M", repair short in Tan wire circuit between ACP and PCM.

9) If voltage is fluctuating between 3 and 5 volts, use jumper wire to connect ACP harness connector terminals C10 and C11. See Fig. 7. Using DVOM, measure voltage at DLC terminal "M". If voltage is fluctuating between 3 and 5 volts, check for faulty ACP connections. If ACP connections are good, replace ACP.

10) If voltage does not fluctuate between 3 and 5 volts at DLC terminal "M", disconnect Electronic Brake Control Module (EBCM) connector. EBCM is mounted to center of cross brace behind rear seat and is accessible from trunk. Using DVOM, measure voltage at DLC terminal "M". If voltage fluctuates between 3 and 5 volts, replace EBCM. If voltage does not fluctuate between 3 and 5 volts, repair short in Tan wire between ACP and DLC terminal "L".

11) Ensure PCM connector and DLC cover are still disconnected. Disconnect Yellow DERM connector. DERM is mounted behind instrument panel above brake pedal. Using DVOM, measure voltage at DERM harness connector terminal A11. See Fig. 8. If voltage does not fluctuate between 3 and 5 volts, go to step 13). If voltage fluctuates between 3 and 5 volts, use jumper wire to connect DERM harness connector terminals A11 and B11. Measure voltage at DLC terminal "M".

12) If voltage fluctuates between 3 and 5 volts at DLC terminal "M", check connections at DERM terminals. If connections are good, replace DERM. If voltage does not fluctuate between 3 and 5 volts at DLC terminal "M", repair short in Tan wire circuit between DERM and DLC. See WIRING DIAGRAMS.

13) Turn ignition off. Disconnect IPC connectors. Leave DERM disconnected. Using DVOM, measure resistance to ground from IPC connector terminal C1. See Fig. 3. If resistance is 2000 ohms or less, repair short in Tan wire circuit between DERM and IPC. See WIRING DIAGRAMS.

14) If resistance is greater than 2000 ohms, connect jumper wire from DERM connector terminal A11 to ground. See Fig. 8. Measure resistance to ground from IPC connector terminal C1. If resistance is more than 2000 ohms, repair open in Tan wire circuit between IPC and

DERM.

15) If resistance is 2000 ohms or less, ensure PCM is still disconnected and measure resistance from ground to IPC harness connector terminal C2. If resistance is now more than 2000 ohms and terminal connections are good at IPC connectors, replace IPC. See INSTRUMENT PANEL CLUSTER under REMOVAL & INSTALLATION.

16) If resistance is now 2000 ohms or less, repair short in Tan wire circuit between IPC and PCM. After all repairs are completed, clear all codes and verify correct operation.

Code I032 - Loss Of ABS/TCS Data (4.6L)

1) If this code is set, IPC is not able to exchange data with EBTCM. While this failure is present, no Electronic Brake & Traction Control Module (EBTCM) diagnostic information will be available for display, BRAKE warning light will be illuminated and IPC will display ANTILOCK DISABLED and TRACTION DISABLED messages. When this code is set by itself, problem will be one of following:

- * An open in Tan wire circuit between EBTCM and DERM and a second open between RSS and EBTCM.
- * An open or short in EBTCM power or ground circuits.
- * A faulty EBTCM.

EBTCM is located in center of electronics bay, mounted on "X" brace. DERM is located below left side of instrument panel, above brake pedal. DERM has Yellow connector and harness.

2) Turn ignition on. Enter self-diagnostics. Record any trouble codes. See ENTERING SELF-DIAGNOSTICS. If Codes I032 and I034 are set, check ground connection at G102 located near rear valve cover on right side of engine. If Codes I032, I033, I034, I037 and I039 are set, go to MULTIPLE DATA COMMUNICATION CODES (4.6L) under TROUBLE CODES.

3) If Code I032 is set by itself, check if code is current or history. If Code I032 is current ("C"), go to next step. If Code I032 is history ("H"), check ignition feed, ground circuit and data circuits for intermittent faults.

4) Disconnect EBTCM. Using a DVOM, measure voltage at EBTCM connector terminal No. 31 (Tan wire). See Fig. 9. If voltage is greater than 3 volts, go to next step. If voltage is less than .1 volt, repair open in Tan wire between EBTCM and DERM and between RSS module and EBTCM.

5) Using a DVOM, measure voltage between EBTCM connector terminals No. 1 (Orange wire) and No. 20 (Black wire). See Fig. 9. If system voltage is present, ensure there is no terminal or connector damage. If connectors and terminals are okay, replace EBTCM. If low voltage is present, check fuse A1 in trunk. If fuse is blown, replace fuse and repair short to ground in Orange wire to EBTCM terminal No. 1. If fuse is okay, check for open in Tan wire. If wire is okay, INSTRUMEI

replace EBTCM.

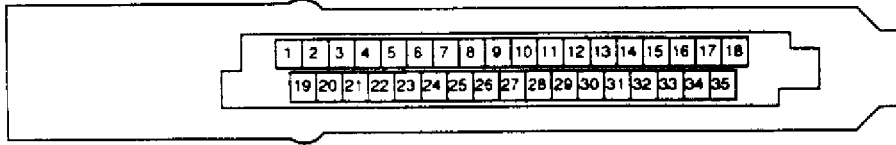

93D41130

Fig. 9: Identifying EBTCM Connector Terminals (4.6L)
Courtesy of General Motors Corp.

Code I033 - Loss Of SIR Data

1) If this code is set with Codes I034, I037, E047 and A037, see MULTIPLE DATA COMMUNICATION CODES under TROUBLE CODES. If this code sets by itself, IPC is not able to exchange data with DERM. IPC will also display SERVICE SUPPLEMENTAL RESTRAINTS message. Problem will be one of following:

- * An open in Tan wire circuit between IPC and DERM and a second open between DERM and ACP.
- * An open in Yellow wire circuit from DERM terminal A9 or A10 to engine compartment fuse block fuse A11.
- * An open in Black/White or Yellow wire.
- * A faulty DERM.

Diagnostic Energy Reserve Module (DERM) is located above brake pedal. DERM has Yellow connector and wiring harness.

2) Turn off ignition and wait for 5 seconds. Turn ignition on and notice inflatable restraint warning light. If warning light does not flash 7-9 times and then go out, see SYSTEM OPERATION CHECK in the AIR BAG RESTRAINT SYSTEM article. If warning light performs normally, enter self-diagnostics.

3) If Code I033 is a current ("C") code, go to next step. If Code I033 is a history ("H") code, check for intermittent problems in power and ground circuits of DERM and in serial data circuit. See WIRING DIAGRAMS.

4) Disconnect Yellow SIR connectors near base of steering column and behind glove box trap door. Disconnect Yellow DERM connector. Using DVOM, measure voltage at DERM harness connector terminal A11. See Fig. 8. If voltage does not fluctuate between 3 and 5 volts, repair open in Tan wire circuit between IPC and DERM. See WIRING DIAGRAMS.

5) If voltage fluctuates between 3 and 5 volts, measure voltage between DERM harness connector terminals A1 and A9. If voltage is 12 volts or more, ensure there is no terminal or connector damage. If connectors and terminals are okay, replace DERM. If voltage is less than 12 volts, go to next step.

6) Using DVOM, measure voltage from harness connector **INSTRUMENT PA**

terminal A9 to ground. If voltage is less than 10 volts, repair short in Yellow wire power circuit from engine compartment fuse block fuse A11 to DERM terminal A9 or A10. If voltage is 10 volts or more, repair Black/White wire ground circuit from DERM terminals A1 and A12. After all repairs are completed, clear all codes and verify correct operation.

Code I034 - Loss Of PCM Data

1) If this code is set with Codes I033, I037, P047 and A037, see MULTIPLE DATA COMMUNICATION CODES. If this code is set by itself, IPC is not able to exchange data with PCM. Problem will be one of following:

- * An open in Tan wire circuit between IPC and PCM, and a second open between PCM and ACP.
- * An open in PCM power or ground circuits. This will also set a Code P052.
- * A faulty PCM or PCM CAL-PAK. CAL-PAK is located inside PCM. PCM is located behind glove box, at top of right kick panel.

2) Start engine. If engine does not start or there is serious driveability complaint, go to the appropriate G - TESTS W/CODES article in the ENGINE PERFORMANCE section.

- G - TESTS W/CODES - 4.6L - Concours
- G - TESTS W/CODES - 4.9L - DeVille

If engine starts, turn engine off. Turn ignition on. Enter self-diagnostics. See ENTERING SELF-DIAGNOSTICS under SELF-DIAGNOSTICS.

3) If Code I034 sets as a current ("C") code (I034C), go to next step. If Code I034 sets as a history ("H") code (I034H), check for Code P052H. If Code P052H is also set, proceed to the appropriate G - TESTS W/CODES article (See above). If P052H is not set, there is an intermittent problem. Check for an open in Tan wire circuit between IPC and PCM.

4) Disconnect PCM connector C2 (middle one). Using DVOM, measure voltage at PCM harness connector C2, terminal 2C12 (4.6L) or terminal A28 (4.9L). See Fig. 4 or 5. If voltage is not fluctuating between 3 and 5 volts, repair open or short in Tan wire circuit between IPC and PCM.

5) If voltage is fluctuating between 3 and 5 volts, ensure terminals and connections are not damaged and that connectors fully seat into PCM. Ensure CAL-PAK is properly installed into PCM and that CAL-PAK pins are fully seated into PCM.

6) If all connections are good and CAL-PAK is properly installed, check for high resistance in PCM ground circuits. Repair as necessary. If ground circuits are okay, replace faulty PCM. After all

repairs are completed, clear all codes and verify correct operation.
Code I037

Loss Of ACP Data

1) If this code is set with any other codes, see appropriate MULTIPLE DATA COMMUNICATION CODES procedure under TROUBLE CODES. If this code is set by itself, IPC is not able to exchange data with ACP. Problem solution will be one of following:

- * An open in Tan wire circuit between ACP and PCM and a second open between ACP and either RSS module (4.6L) or DERM (4.9L).
- * An open in ACP power or ground circuits.
- * A faulty ACP.

Diagnostic Energy Reserve Module (DERM) is located directly above brake pedal. DERM has Yellow connector and wiring harness. A/C Programmer (ACP) is located to left of PCM, behind glove box.

2) When this code is present, Climate Control Center (CCC) panel will display "- - -" for outside and set temperatures, defrost mode will be selected, A/C clutch will be disabled and blower will run at constant 6 volts.

3) Enter self-diagnostics. See ENTERING SELF-DIAGNOSTICS under SELF-DIAGNOSTICS. If Code I037 sets as a current ("C") code (I037C), go to step 5). If Code I037 sets as a history ("H") code (I037H), there is an intermittent problem. Locate ACP connector.

4) If only Code I037 is set, check for power to ACP by backprobing ACP connector terminals C12 (Brown wire) and C13 (Orange wire) for battery voltage when ignition is in RUN position. See Fig. 7. Check ACP connector terminal C1 for ground continuity. Check across ACP connector terminals C10 and C11 for open in serial data line circuit. Check for an open in Tan wire circuit between ACP and PCM.

5) Remove ACP harness connector. Using DVOM, measure voltage at ACP harness connector terminal C11 (Tan wire). See Fig. 7. Terminal C11 (Tan wire) is serial data line to IPC. If voltage does not fluctuate between 3 and 5 volts at this terminal, repair open in Tan wire circuit between ACP and PCM.

6) If voltage is fluctuating between 3 and 5 volts, measure voltage between ACP harness connector terminals C13 and C1, and between C12 and C1. If both voltage tests are less than 10 volts, repair ground in Black/White wire circuit from terminal C1. If only terminal C12 has less than 10 volts, repair ignition power circuit (Brown wire).

7) If only C13 has less than 10 volts, repair short in battery power circuit (Orange wire). If both voltage tests are 10 volts or more, ensure no terminal or connector damage is present. If connectors and terminals are okay, replace ACP.

Code I039 - Loss Of RSS Data (4.6L)

1) If this code is set with any other codes, see MULTIPLE DATA COMMUNICATION CODES (4.6L) under TROUBLE CODES. If this code is set by itself, IPC is not able to exchange data with Road Sensing Suspension (RSS) module. Message SERVICE RIDE CONTROL will be displayed in Driver Information Center (DIC). Problem will be one of following:

- * Opens in Tan wire between EBTCM and RSS module and between RSS module and ACP.
- * Open or short in power or ground circuits of RSS module.
- * Faulty RSS module.

2) Turn ignition on. Enter diagnostics. See ENTERING SELF-DIAGNOSTICS under SELF-DIAGNOSTICS. If Code I039 is current ("C"), go to next step. If Code I039 is stored as history ("H"), fault is not present.

3) Using a DVOM connected to ground, backprobe for voltage at RSS module connector C2 terminal D1 (Orange wire) and D5 (Brown wire). See Fig. 10. If system voltage is present at both terminals, go to step 7). If low voltage is present at terminal D5, go to step 5). If low voltage is present at terminal D1, go to next step.

4) Check fuse C5 in engine compartment fuse block. If fuse is blown, repair short to ground in Orange wire between RSS module and fuse. If fuse is okay, repair open in Orange wire.

5) Check engine compartment fuse A3. If fuse is okay, repair open in Brown wire between RSS module and fuse. If fuse is blown, turn ignition off. Disconnect RSS module connector C2. Using a DVOM, check for continuity to ground at RSS module connector C2 fused circuits. See Fig. 11.

6) If continuity is present on either circuit, repair short to ground in Brown or White wire. If no continuity is present on either circuit, check for intermittent short to ground in both wires.

7) Disconnect RSS module connector C1. Turn ignition on. Using DVOM, measure voltage to ground at RSS module connector C1 terminals D9 and D8. If voltage fluctuates between 3 and 5 volts, go to next step. If voltage is less than 3 volts, repair open in Tan wire between ACP and RSS module and between EBTCM and RSS module.

8) Turn ignition off. Using a DVOM, measure resistance between ground and RSS module connector C3 terminal "G" (Black wire). See Fig. 12. Repair Black wire if resistance is greater than one ohm. If resistance is less than one ohm, check for improper terminal contact and connector damage. If contact and connector are okay, replace RSS module. After all repairs are completed, clear all codes and verify correct operation.

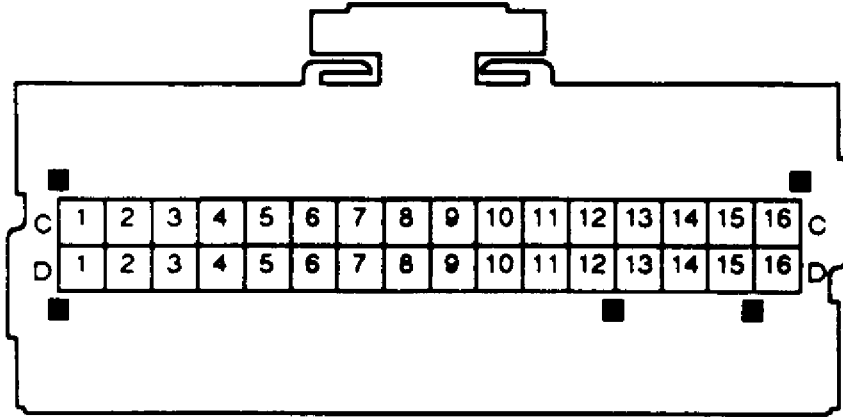

CONNECTOR C1 (BLUE)

94B32590

Fig. 10: Road Sensing Suspension (RSS) Module Connector Terminals (C1)

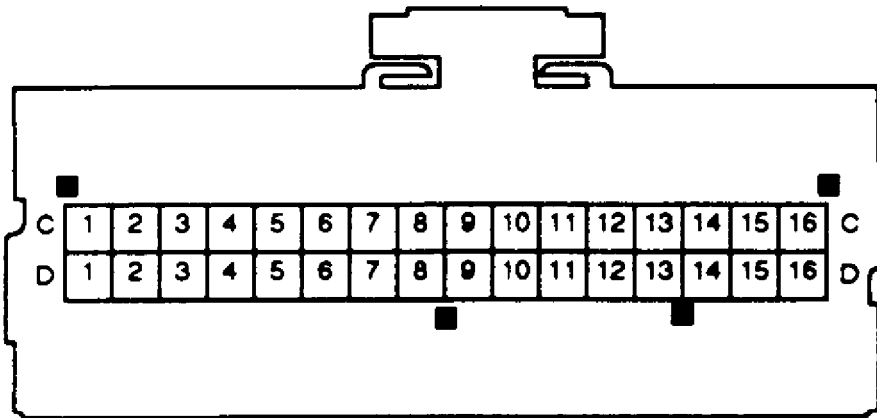

CONNECTOR C2 (BLACK)

94C32591

Fig. 11: Road Sensing Suspension (RSS) Module Connector Terminals (C2)

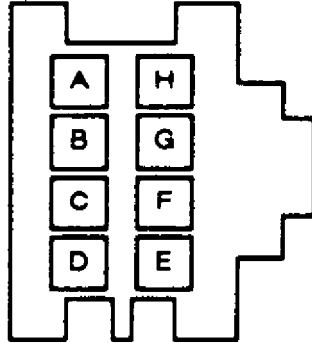

CONNECTOR C3 (BLACK)

94E32593

Fig. 12: Road Sensing Suspension (RSS) Module Connector Terminals (C3)

Code I039 - SSS Signal Fault (4.9L)

1) This code will normally set during Speed Sensitive Suspension (SSS) diagnostics. If SSS diagnostics were recently performed, clear codes first, test drive vehicle and recheck trouble codes. When this code failure is present, DIC will display SERVICE RIDE CONTROL warning.

2) This code will set if voltage of Red wire between IPC and SSS control module goes low when vehicle is greater than 15 MPH or if voltage is high when vehicle speed is less than 5 MPH. Possible causes of this code are:

- * SSS fault detected by SSS control module.
- * SSS diagnostic mode entered.
- * Loss of IPC vehicle speed information.
- * Open or short in Red, Brown or Dark Green/White wire circuit.
- * Faulty SSS control module.

3) Enter diagnostics. See ENTERING SELF-DIAGNOSTICS. If Code E024 is also set, a vehicle speed sensor may be at fault. See the G - TESTS W/CODES - 4.9L article in the ENGINE PERFORMANCE section.

~~IN Code E024 is not set and speedometer does not function, see INSTRUMENT PANEL Article Text (p. 44) 1995 Cadillac Concours For Ace Mechanics 123 Main Street San Diego Ca 92~~
SPEEDOMETER INOPERATIVE/INACCURATE under IPC TESTS under COMPONENT TESTING.

4) If Code P024 is not set and speedometer functions properly, repair Speed Sensitive Suspension (SSS) system. See the appropriate SUSPENSION - REAR ELECTRONIC article in the SUSPENSION section. After all repairs are completed, clear all codes and verify correct operation.

Code I041 Or I042 - Battery Voltage Too Low Or Too High

1) These codes will set when engine speed is greater than 800 RPM, the IPC can communicate with PCM (Code I034 is not set) and ignition voltage at IPC is outside normal limits for more than 2 seconds. If voltage is less than 10.6 volts, Code I041 will set and DIC display will show BATTERY VOLTS LOW. If voltage is greater than 16 volts, Code I042 will set and DIC display will show BATTERY VOLTS HIGH. If voltage falls below 9 volts, IPC will not function.

2) Start engine and operate at 1200-1500 RPM. Enter diagnostics. Note and record data values for ID50 and ED10. See the appropriate G - TESTS W/CODES article in the ENGINE PERFORMANCE section.

G - TESTS W/CODES - 4.6L - Concours
G - TESTS W/CODES - 4.9L - DeVille

Compare data value readings. If PCM and IPC are not "seeing" same battery voltage, then IPC internal voltage sensor, and/or IPC ground is faulty.

3) If data values are within one volt of each other, go to next step. If either value is greater than the other by one volt or more, use DVOM to check for battery voltage at IPC connector terminal C13. See Fig. 3. Also using DVOM, check IPC connector terminals C16 and A5 for continuity to ground. Repair circuits if continuity is not present.

4) If ID50 data value is less than 10 volts or greater than 16 volts, repair charging system. If ID50 data value is 10-16 volts, turn on all accessories and operate engine at idle for more than 60 seconds. Note ID50 data value. If data value is now less than 10 or greater than 16 volts, repair charging system. If data value is still 10-16 volts, turn off all accessories and go to next step.

5) Continue to operate engine at 1200-1500 RPM for more than one minute. Note and record ID50 data value. If data value is less than 10 volts or greater than 16 volts, repair charging system. If data value is still 10-16 volts, problem is intermittent. Observe IPC I041/I042 snapshot data value for ID50. This is voltage at the time the codewas set.

6) Also "look" at snapshot information for parameters ID60 (vehicle speed), II94 (parking lights on/off), and II10 (alternator feedback) to help determine when code is being set. Ensure IPC terminal connections are good and that grounds are tight. After all repairs are completed, clear all codes and verify correct operation.

Code I052 - Keep Alive Memory Error

A Code I052 indicates "keep alive" or "long term" memory in IPC has been reset. This code will set anytime battery is disconnected. When code is set, IPC memory resets itself to initial values, eliminating any driver-desired changes. If Code I052 sets and it is known that the battery has not been disconnected, check contacts

at IPC connector terminals A1 and C12. Also check ground continuity of terminals A5 and C16. See Fig. 3.

Code I056 - IPC EEPROM Error

This code sets when IPC cannot "read" elapsed odometer mileage in EEPROM. ERROR will be displayed in odometer display when code is set. Check IPC harness connections and EEPROM insertion into IPC. If connections are good and secure, replace IPC.

REMOVAL & INSTALLATION

CLIMATE CONTROL CENTER & DRIVER INFORMATION CENTER

Removal & Installation

These 2 units are integral components of instrument cluster. If either unit must be replaced, replace complete instrument cluster assembly. See INSTRUMENT PANEL CLUSTER.

HEADLIGHT/TWILIGHT SENTINEL SWITCH MODULE

Removal & Installation

Remove headlight switch module from instrument panel by carefully, yet firmly, pulling outward on switch knob while prying on module's opposite side to remove switch from panel. See Fig. 13. Disconnect both wiring connector retaining clips. Carefully pull connectors straight back away from switch pins. Remove switch. To install, reverse removal procedure.

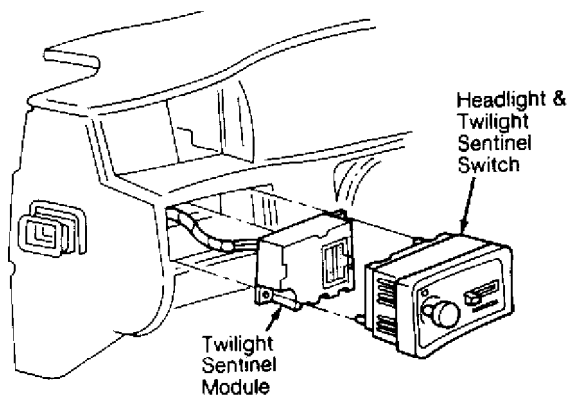

Fig. 13: Removing Headlight Switch Module (Typical)
Courtesy of General Motors Corp.

INSTRUMENT PANEL CLUSTER

Removal & Installation

1) Remove fuses A5 and B5 from trunk mounted fuse panel. Remove fuse A3 from engine compartment fuse panel. Remove instrument panel top cover. See INSTRUMENT PANEL TOP COVER.

INSTRUM

2) Disconnect 2 harness connectors from top, rear of cluster. Remove 4 cluster retaining screws. See Fig. 14. On electronic cluster, lift cluster slightly to remove PRNDL unit screws from bottom of cluster. On both clusters, lift cluster straight up and out of instrument panel.

3) To install, reverse removal procedure. Ensure electrical connectors are properly aligned with instrument cluster to prevent pin breakage. After installation, perform self-diagnostics light segment check. See ENTERING SELF-DIAGNOSTICS under SELF-DIAGNOSTICS.

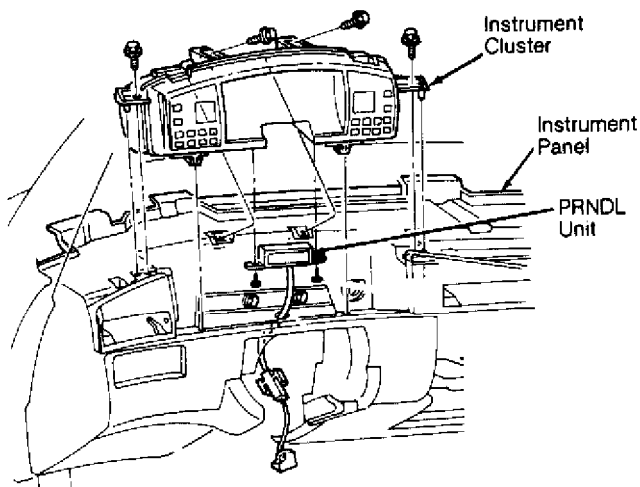

Fig. 14: Removing Instrument Cluster
Courtesy of General Motors Corp.

INSTRUMENT PANEL TOP COVER

Removal & Installation

1) Raise long defroster grille by carefully prying upward using small, flat-blade screwdriver. See Fig. 15. Depending on interior trim, sunload sensor and twilight sentinel photocell may need to be removed from bottom of defroster grille, before removing grille from vehicle. See Fig. 16.

2) Remove 3 top cover retaining screws from inside defroster grille opening. Remove A/C vent outlet grilles from front of panel by gently prying inward on each side of grille to release retaining tabs. Pull grilles straight out from panel openings.

3) Remove 4 top cover retaining screws from inside grille openings. Remove top cover from instrument panel using care not to scratch windshield pillars. To install, reverse removal procedure.

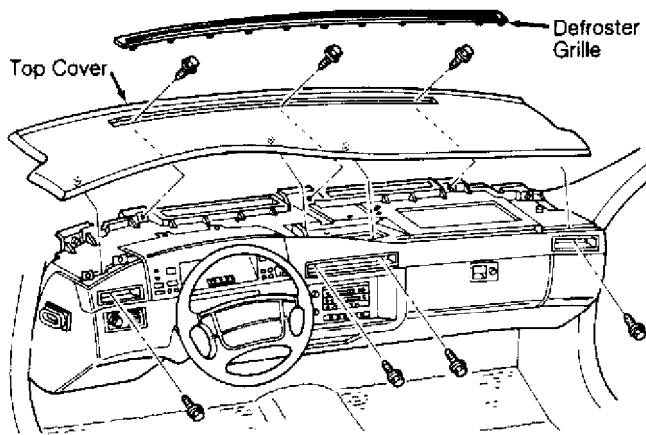

Fig. 15: Removing Instrument Panel Top Cover
 Courtesy of General Motors Corp.

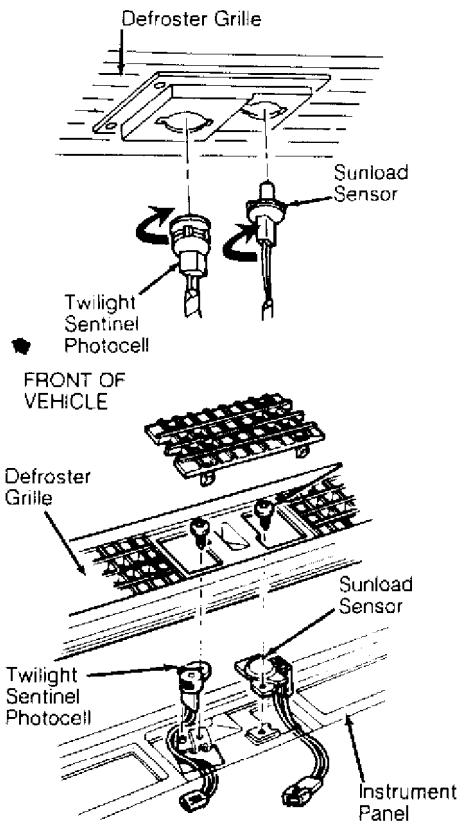

Fig. 16: Removing Sunload Sensor & Twilight Sentinel Photocell
 Courtesy of General Motors Corp.

TURN SIGNAL FLASHER UNIT & HAZARD FLASHER UNIT
 INSTRUMENT PANEL (p. 48) 1995 Cadillac Concours For Ace Mechanics 123 Main Street San Diego Ca 92

Removal & Installation

1) Remove left sound insulator from left lower instrument panel, underneath steering column. Remove steering column opening trim by pulling downward away from slots in steering column opening bracket. See Fig. 17.

2) Remove 4 retaining screws from steering column opening bracket and remove. Locate turn signal or hazard flasher unit. See Fig. 18. Disconnect harness connector and remove desired unit. To install, reverse removal procedure.

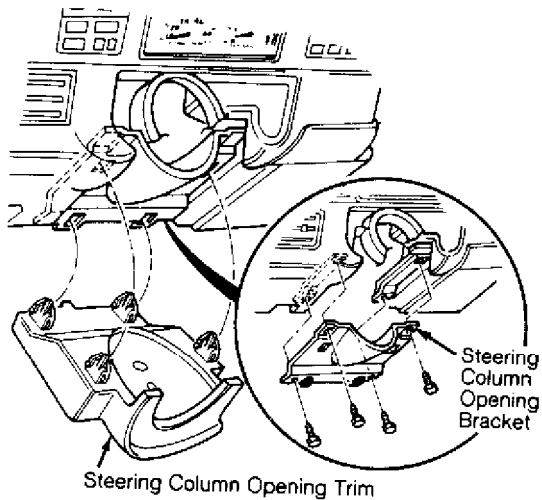

Fig. 17: Removing Steering Column Opening Trim & Bracket
Courtesy of General Motors Corp.

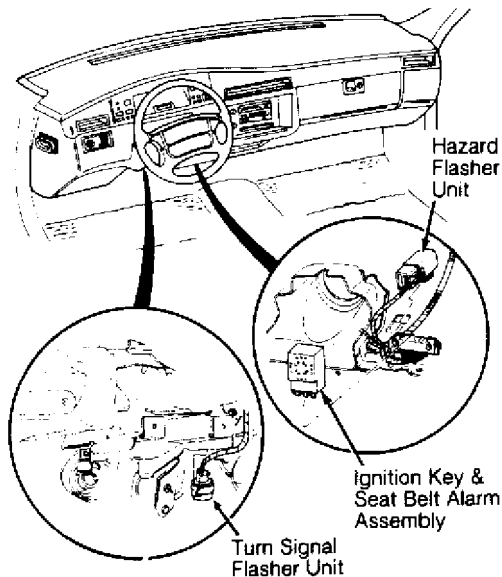

Fig. 18: Removing Turn Signal & Hazard Flashers
Courtesy of General Motors Corp.

WIRING DIAGRAMS

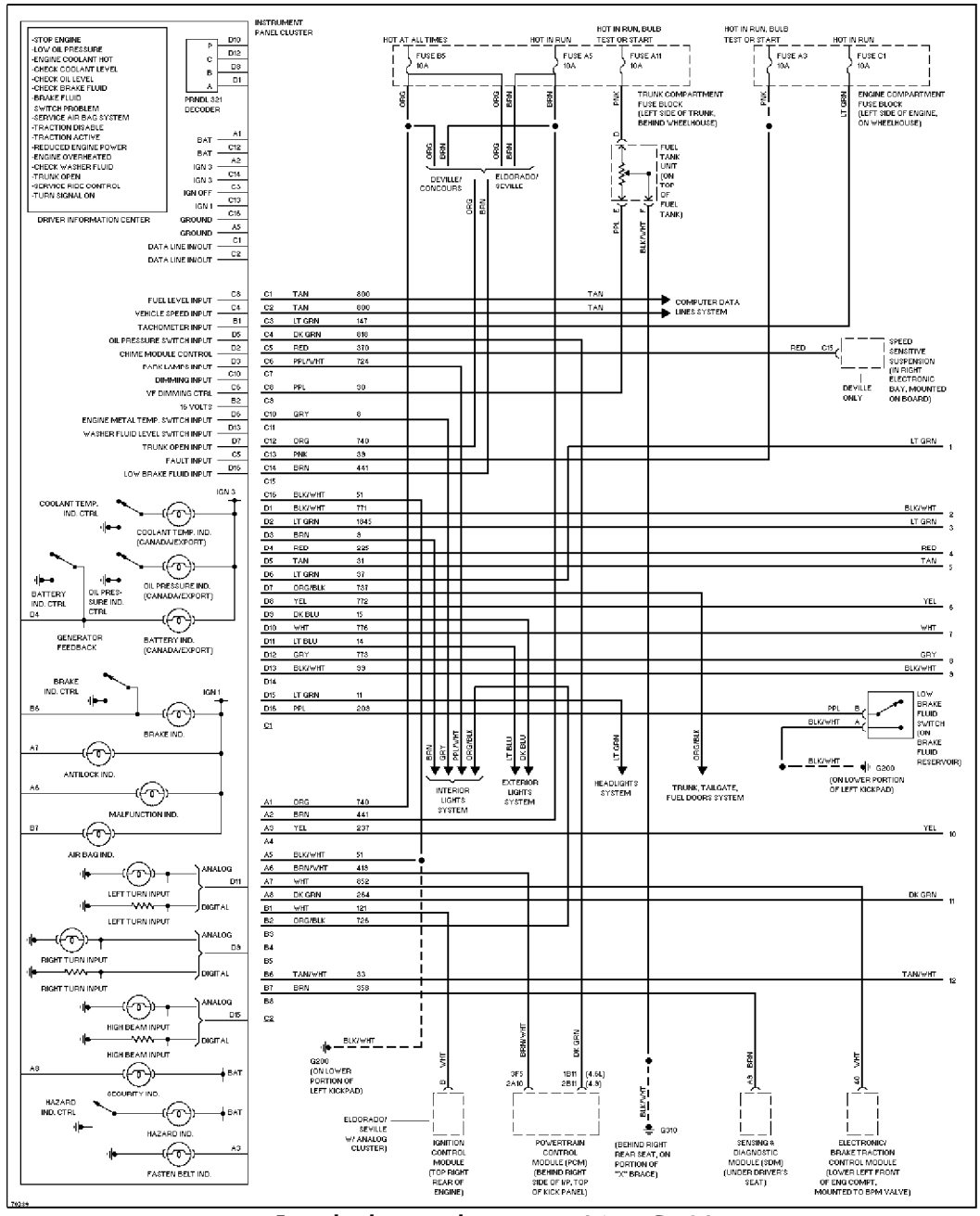

Fig. 19: Instrument Panel Wiring Diagram (1 Of 2)

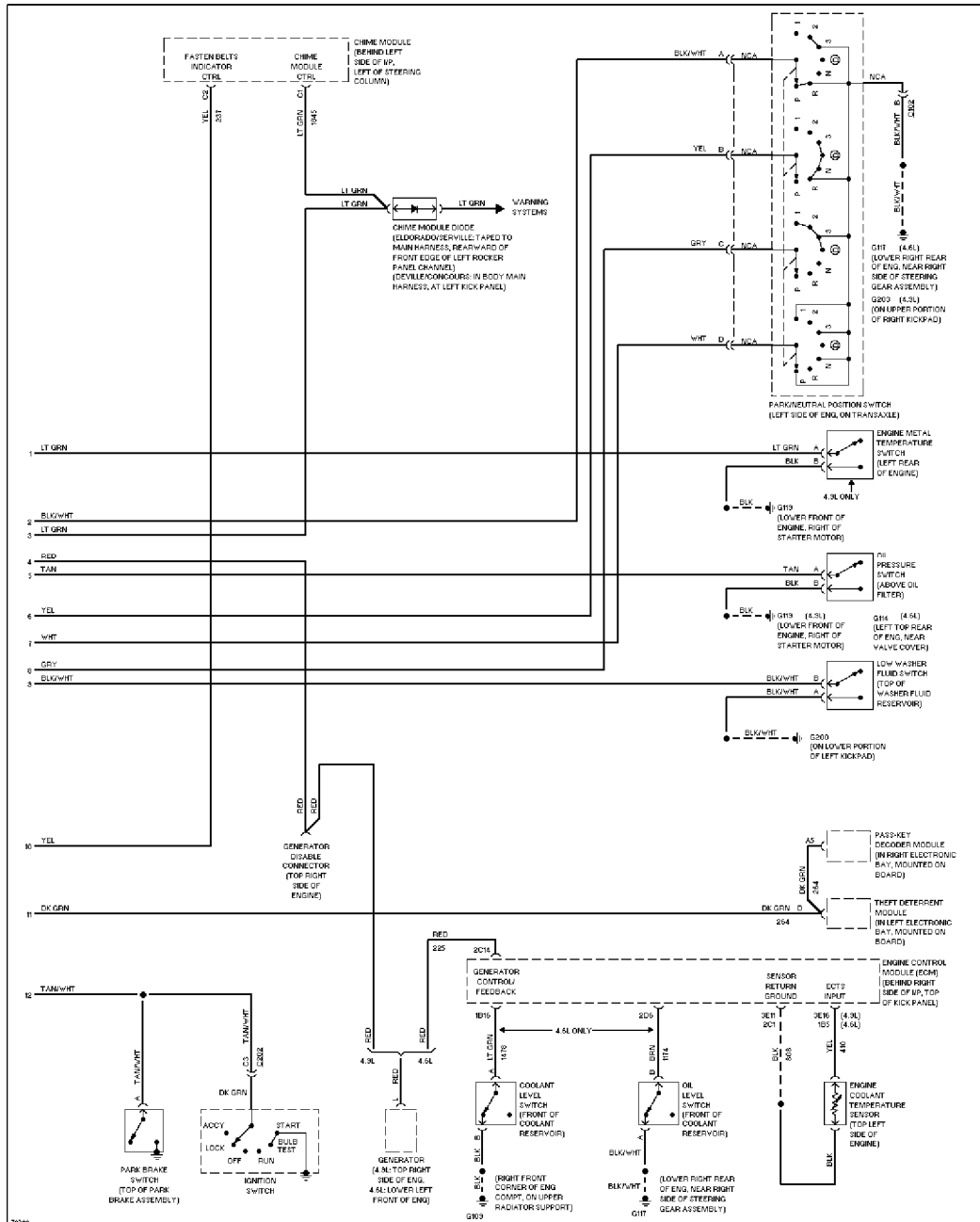

Fig. 20: Instrument Panel Wiring Diagram (2 Of 2)
INSTRUMENT PANEL Article Text (p. 51) 1995 Cadillac Concours For Ace Mechanics 123 Main Street San Diego Ca 92
END OF ARTICLE