

## 4.6L V8 - VIN [Y]

### Article Text

1995 Cadillac Concours  
For Ace Mechanics 123 Main Street San Diego Ca 92126  
Copyright © 1997 Mitchell International  
Friday, November 28, 2003 07:43PM

#### ARTICLE BEGINNING

1995 GENERAL MOTORS ENGINES  
4.6L V8 - VIN Y

Cadillac: Concours, Eldorado, Seville

\*\*\* PLEASE READ THIS FIRST \*\*\*

**NOTE:** For repair procedures not covered in this article, see ENGINE OVERHAUL PROCEDURES - GENERAL INFORMATION in the GENERAL INFORMATION section.

#### ENGINE IDENTIFICATION

Engine can be identified by eighth character of Vehicle Identification Number (VIN) stamped on a metal pad, located on top of dash, near left end of windshield. If eighth character of VIN is "Y" (RPO Code LD8), engine is a 4.6L V8 Northstar. Also, an "S" in tenth character of VIN indicates 1995 model year.

#### ADJUSTMENTS

##### VALVE CLEARANCE ADJUSTMENT

Hydraulic lifters are used. No valve adjustments are required.

#### REMOVAL & INSTALLATION

**CAUTION:** When battery is disconnected, vehicle computer and memory systems may lose memory data. Driveability problems may exist until computer systems have completed a relearn cycle. See COMPUTER RELEARN PROCEDURES article in the GENERAL INFORMATION before disconnecting battery.

**NOTE:** For reassembly reference, label all electrical connectors, vacuum hoses and fuel lines before removal. Also place mating marks on engine hood and other major assemblies before removal.

##### FUEL PRESSURE RELEASE

Loosen fuel tank filler cap to relieve tank pressure. Turn ignition off. Disconnect negative battery cable. Connect Gauge (J-34730-1) to fuel pressure test port (to avoid spillage, wrap a shop towel around fitting while connecting gauge). Insert bleed hose into

an approved container. Open valve to bleed system pressure. Drain any fuel remaining in gauge into an approved container.

#### COOLING SYSTEM BLEEDING

1) After servicing cooling system, use this procedure to ensure all air has been bled from system. If system was drained, disconnect lower radiator hose, add 3 pellets of GM Coolant Supplement (3634621) to lower radiator hose, then reconnect hose.

2) In any case, add a 50/50 mixture of coolant to surge tank until system (including surge tank) is full. Start engine. Set climate control to any mode except MAX. Set temperature to highest setting.

3) Run engine at idle until lower radiator hose is hot. Add coolant to surge tank until tank is full. Install surge tank cap (align arrows on cap with overflow hose). Allow engine to cool. Fill overflow reservoir to FULL COLD mark.

#### ENGINE

##### Removal

1) Scribe line around hinge on inner hood panel for reassembly. Remove hood light connector and hood supports. With the aid of a helper, remove hinge-to-hinge bolts and hood. Remove brace between shock towers.

2) Relieve fuel system pressure. See FUEL PRESSURE RELEASE. Remove air cleaner inlet duct. Drain engine coolant. Remove left and right engine torque strut rods. Reinstall bolt in torque strut bracket on left side of engine to be used as an engine lift point.

3) Disconnect radiator hoses at water crossover. Remove both cooling fans. Remove serpentine accessory drive belt. Disconnect cruise control servo connections. Disconnect Idle Speed Control (ISC) motor electrical connector.

4) Hold throttle completely open, and push throttle cable toward intake manifold until released. DO NOT kink cable. DO NOT use screwdriver or other sharp tool for removing cable.

5) Disconnect shift cable from park/neutral switch and cable bracket at transmission. Remove park/neutral switch. Disconnect power brake hose. Remove intake manifold. See INTAKE MANIFOLD.

6) Remove starter motor. Disconnect cylinder head temperature switch at rear of right head. Remove bellhousing bolts. Remove ignition coils and spark plug wires. Raise vehicle.

7) Remove oil pan-to-transmission brace. Remove torque converter splash shield, and remove 4 converter-to-flywheel bolts. Disconnect oil cooler lines at oil filter adapter. Remove A/C compressor mounting bolts and electrical connections. Set compressor aside.

8) Disconnect electrical connections from left side of engine. Move harness from behind exhaust manifold. Remove 2 nuts

securing motor mount to engine cradle front crossmember. Remove "Y" pipe.

9) Remove right front wheel. At transmission tail shaft, remove bracket securing crankcase to transmission. Disconnect knock sensor. Disconnect brace securing transmission to cylinder head. Lower vehicle.

10) Disconnect fuel inlet and return lines using Fuel Line Disconnecter (J-37088). Disconnect injector harness connector. Disconnect hoses from coolant reservoir. Remove coolant reservoir. Disconnect camshaft position sensor. Disconnect heater hoses from water pipes at front end of right cylinder head.

11) Disconnect battery cable from junction block, and remove retainer at cylinder head. Disconnect fluid lines from power steering pump. Disengage power steering line from retainer. Disconnect rear oxygen sensor connector. Remove 3 screws securing wiring harness retainer to right camshaft cover, then position harness aside.

12) Connect an engine lifting fixture to engine using support hooks at left rear and right rear of engine. Use torque strut bracket at left front of engine for a third lift point. A load-tilting device such as Kent-Moore (J-39456) will provide needed adjustment. Carefully remove engine, as space is very limited.

#### Installation

Carefully lower engine into position. Install bell-housing bolts. Loosely install 2 nuts to motor mount at front of axle. Install one bolt to cylinder head for transmission brace. Install 4 bolts securing transmission bracket to crankcase. Tighten fasteners to specification. See TORQUE SPECIFICATIONS. To complete installation, reverse removal procedure.

#### INTAKE MANIFOLD

##### Removal

1) Relieve fuel system pressure. See FUEL PRESSURE RELEASE. Remove sight shield (decorative shield) from above intake manifold. Disconnect air intake duct from throttle body. Disconnect transaxle vent hose and shift cable at bracket. Disconnect electrical connectors from throttle position sensor and idle air control valve.

2) Disconnect accelerator cable and cruise control cable at throttle body. Disconnect spark plug wires from plugs in left cylinder head. Disconnect coolant hoses at throttle body and surge tank. Disconnect EGR pipe and crankcase ventilation pipe from throttle body spacer. Disconnect brake booster vacuum hose from intake manifold.

3) Disconnect fuel rail ground wire from right cylinder head. Disconnect fuel line quick-connect fittings at fuel rail. Disconnect fuel rail bracket at EGR valve. Disconnect PCV hose from intake manifold. Disconnect fuel injector harness main connector. Remove bolts/studs and intake manifold.

NOTE: Gaskets are secured to intake manifold with a snap lock. If plastic housing or rubber seals are not damaged, re-use gaskets.

CAUTION: If throttle body was removed, DO NOT reuse old "O" ring seal. DO NOT apply silicone lubricant to "O" ring seal.

#### Installation

If the throttle body was removed, position a NEW throttle body "O" ring seal on the throttle body with petroleum jelly. Install intake manifold. Tighten intake manifold bolts to specification in several phases (start with inner bolts and work outward). Refer to TORQUE SPECIFICATIONS. To complete installation, reverse removal procedure.

### EXHAUST MANIFOLD

#### Removal & Installation (Left)

1) Remove radiator cradle beauty panel. Remove air cleaner assembly. Disconnect left and right engine torque strut rods, and position them aside. Remove engine cooling fans. Support engine from above using Engine Support Fixture (J-28467-A). Raise vehicle on hoist.

2) Remove 2 nuts securing motor mount to engine cradle. Remove 2 bolts securing motor mount bracket to crankcase. Remove 2 bolts securing motor mount bracket to cylinder head. Remove 2 nuts securing motor mount to motor mount bracket.

3) Disconnect exhaust "Y" pipe from catalytic converter. Position catalytic converter aside. Lower vehicle. Raise engine by adjusting engine support fixture. Remove motor mount and bracket. Raise vehicle. Remove 4 bolts securing rear alternator bracket. Remove 2 bolts securing exhaust crossover pipe to manifold. Disconnect oxygen sensor connector.

4) Remove nuts, exhaust manifold, and gasket. Discard gasket if damaged. To install, reverse removal procedure. Tighten manifold nuts to specification. See TORQUE SPECIFICATIONS.

#### Removal & Installation (Right)

1) Disconnect oxygen sensor harness from clip at right camshaft cover. Raise vehicle on hoist. Disconnect exhaust "Y" pipe from catalytic converter. Position catalytic converter aside. Disconnect electrical connector from suspension position sensor at each lower control arm.

2) Disconnect intermediate steering shaft from steering rack. Support rear crossmember of engine cradle with a tall screw jack. Remove 4 bolts securing engine cradle to body. Lower rear of engine cradle. Disconnect exhaust pipe

3) Remove nuts, exhaust manifold, and gasket. Discard gasket if damaged. To install, reverse removal procedure. Tighten manifold nuts to specification. See TORQUE SPECIFICATIONS.

## CYLINDER HEAD

### Removal

1) Remove engine. See ENGINE. Remove intake manifold, camshaft covers, harmonic balancer, front cover, and oil pump. See the following:

- \* INTAKE MANIFOLD
- \* CAMSHAFT COVER
- \* HARMONIC BALANCER
- \* FRONT COVER
- \* OIL PUMP

2) Remove timing chain tensioner from cylinder head being removed. See TIMING CHAIN TENSIONER. Remove camshaft sprockets from cylinder head being removed (timing chain remains in chain case). Remove timing chain guides (to access retaining screws, remove plugs at front of cylinder head).

3) Remove water crossover. Remove exhaust manifold. See appropriate EXHAUST MANIFOLD. Remove cylinder head bolts in reverse order of tightening sequence. See Fig. 1. Discard cylinder head bolts; DO NOT reuse them. Remove cylinder head and gasket.

**CAUTION:** When camshafts are in cylinder head, some of the open valves protrude below cylinder head gasket surface. DO NOT set cylinder head face down, or valves will be damaged.

### Installation

Clean bolt holes in cylinder block. Set the cylinder head onto the cylinder block using a NEW gasket. Install and tighten NEW bolts to specification in sequence. See TORQUE SPECIFICATIONS. Refer to Fig. 1. To complete installation, reverse removal procedure.

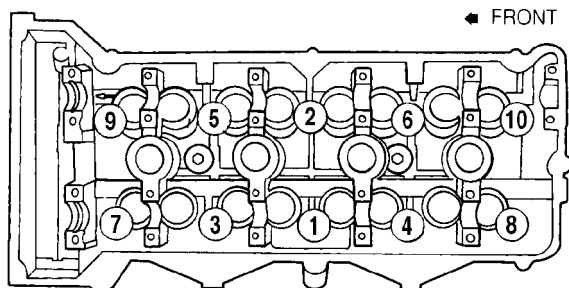

94.133695

Fig. 1: Cylinder Head Bolt Tightening Sequence  
Courtesy of General Motors Corp.

## FRONT COVER

### Removal

Remove serpentine belt. Remove bolt securing power steering hose (if necessary). Remove harmonic balancer. See HARMONIC BALANCER. Remove serpentine belt tensioner and idler pulley. Remove front cover and gasket (gasket is reusable; DO NOT discard unless damaged).

### Installation

Clean gasket surfaces. Apply a small dab of RTV sealer at split line between upper and lower crankcases. Install front cover. Tighten bolts to specification. See TORQUE SPECIFICATIONS. To complete installation, reverse removal procedure.

## CRANKSHAFT FRONT SEAL

### Removal

Remove harmonic balancer. See HARMONIC BALANCER. Carefully pry out seal with a screwdriver or pry bar (DO NOT gouge front cover bore or crankshaft).

### Installation

Lubricate seal lips with engine oil. Position seal with garter spring toward engine. Using Seal Installer (J-38818) and Harmonic Balancer Installer (J-39344), push seal into front cover until installer bottoms. To complete installation, reverse removal procedure.

## SECONDARY TIMING CHAIN

**NOTE:** This procedure applies to both secondary chains.

### Removal

1) Rotate crankshaft until cylinder No. 1 is at TDC of compression stroke. Remove front cover. See FRONT COVER. Remove camshaft cover. See CAMSHAFT COVER. Remove bolts and secondary timing chain tensioner.

2) To access upper chain guide bolts, remove plastic plugs from holes in cylinder head. Remove bolts and upper chain guide. Remove camshaft sprocket bolts and sprockets. Remove secondary drive chain.

### Installation

Set camshaft timing. See CAMSHAFT. Install front cover. Refer to FRONT COVER. Install camshaft cover(s). Refer to procedures under CAMSHAFT COVER.

## TIMING CHAIN TENSIONER

**NOTE:** This procedure applies to all 3 timing chain tensioners.

#### Removal

Remove front cover. See FRONT COVER. Remove 2 bolts and tensioner.

#### Installation

- 1) Collapse tensioner before installing. Rotate ratchet release lever counterclockwise and hold. See Fig. 2.
- 2) Collapse tensioner shoe and hold. Release ratchet lever and slowly release pressure on shoe. As ratchet lever moves to first click, hold tensioner shoe inward and insert a pin through hole in release lever.
- 3) Locked ratchet mechanism should hold shoe in collapsed position. Install tensioner and bolts and tighten to specification. See TORQUE SPECIFICATIONS. Remove retaining pin allowing tensioner shoe to extend. Install front cover. See FRONT COVER.

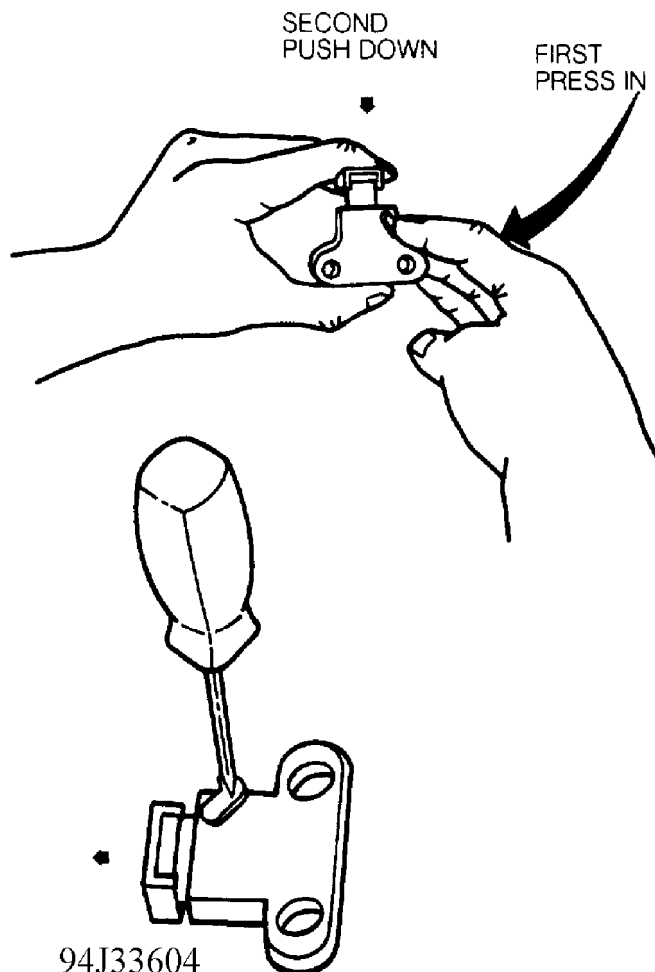

94J33604

**Fig. 2: Collapsing Timing Chain Tensioner**  
Courtesy of General Motors Corp.

## PRIMARY TIMING CHAIN

### Removal

1) Remove the engine and mount it on an engine stand. See ENGINE. Remove serpentine drive belt, idler pulley and belt tensioner. Remove the front cover. See FRONT COVER. Remove the oil pump. Refer to OIL PUMP under ENGINE OILING. Remove the camshaft covers. Refer to CAMSHAFT COVER.

2) Remove all 3 timing chain tensioners. Remove camshaft sprocket bolt from all 4 camshafts, and remove sprockets. Remove secondary drive chains from intermediate shaft sprocket.

3) Remove bolt from intermediate shaft sprocket. Slide gears and primary drive chain off crankshaft and intermediate shaft. Unless wear is evident, it is not necessary to remove intermediate shaft.

### Installation

Set camshaft timing. See CAMSHAFT in this article. Install front cover. Refer to FRONT COVER. Install camshaft covers. Refer to CAMSHAFT COVER.

## CAMSHAFT COVER

### Removal (Left)

1) Disconnect battery. Partially drain coolant from radiator. Disconnect upper radiator hose at water crossover. disconnect spark plug wires.

2) Remove right fan. Disconnect battery cable at generator. Disconnect cable harness cup at camshaft cover and position aside. Disconnect PCV fresh air tube from camshaft cover.

3) Remove left and right torque struts. Disconnect water pump drive belt. Using Pulley Remover (J-38825), remove water pump pulley. Remove camshaft seal retainer screws and remove seal. Disconnect battery cable retainer at front of camshaft cover. Remove camshaft cover screws.

4) Remove camshaft cover by moving camshaft drive end of cover up and then pivot entire cover around water pump drive shaft. Continue moving cover upward and pivoting so that edge of cover closely follows left edge of intake manifold cover. See Fig. 3. Discard cover seal if there is any evidence of damage or if seal comes out of groove in cover during removal. Spark plug seals may be re-used if undamaged.

### Installation

1) Install spark plug and camshaft cover seals as required. Insert intake camshaft through hole in camshaft cover and, using fingers, guide the camshaft cover up over the edge of the cylinder head. See Fig. 3. Use care to prevent exposed section of camshaft cover seal from being damaged by edge of cylinder head casting. Work

cover into position by allowing top edge of cover to follow left edge of intake manifold.

2) Install camshaft cover screws and tighten to specification. See TORQUE SPECIFICATIONS. To complete installation, reverse removal procedure. Install water pump pulley using Pulley Installer (J-38823). Tighten all fasteners to specification. See TORQUE SPECIFICATIONS.

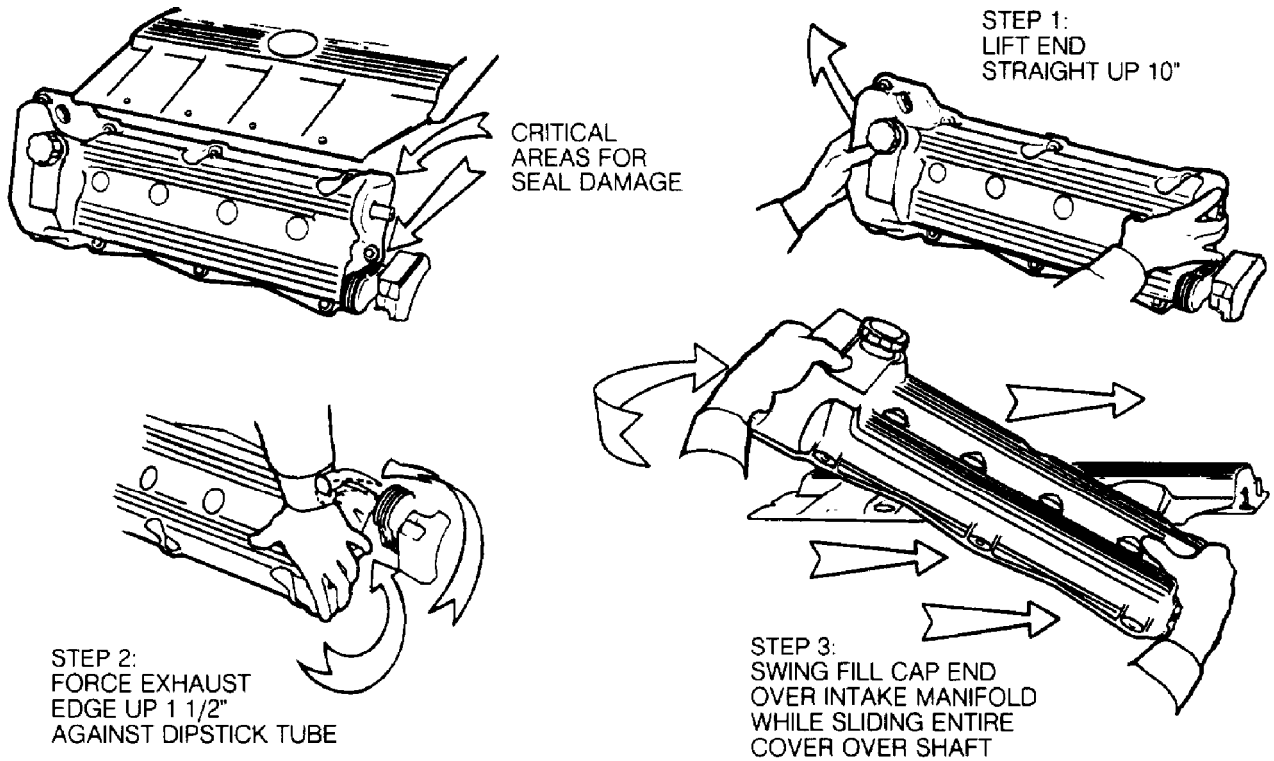

94G33585

REMOVAL

Fig. 3: Removing & Installing Left Camshaft Cover (1 of 2)  
Courtesy of General Motors Corp.

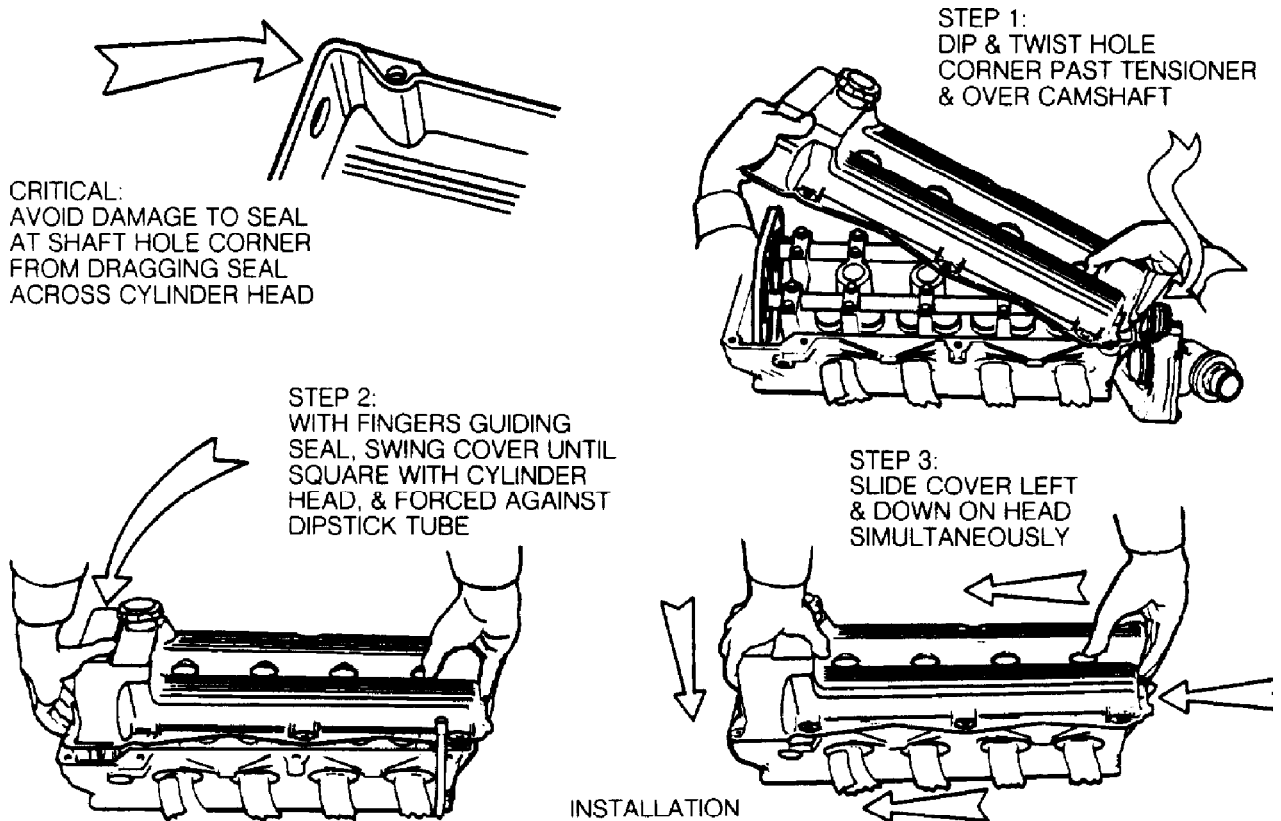

94H33586

Fig. 4: Removing & Installing Left Camshaft Cover (2 of 2)  
Courtesy of General Motors Corp.

#### Removal (Right)

1) Disconnect Battery. Raise vehicle, and disconnect exhaust "Y" pipe at converter. Position converter aside. Lower vehicle.

2) Remove tower-to-tower brace. Disconnect Distributorless Ignition System (DIS) wiring connectors (4) and mounting bolts (5).

Remove DIS and right bank spark plug wires. Disconnect PCV valve.

3) Remove purge canister solenoid from rear of cover. Remove 3 screws securing wiring harness to cover. Remove camshaft cover screws.

4) Support front of engine cradle, and remove 2 mounting screws at front of cradle. Remove left and right torque struts. Lower cradle (or raise vehicle) to provide clearance at rear of engine compartment. Remove camshaft cover. Discard cover seal if there is evidence of damage or if seal comes out of groove in cover during removal. Spark plug seals may be reused if undamaged.

#### Installation

To install, reverse removal procedure. Tighten all fasteners to specification. See TORQUE SPECIFICATIONS.

**CAUTION:** If sprocket/chain relationship is not maintained throughout this procedure, camshaft timing will be lost, requiring further engine disassembly to set camshaft timing.

#### Removal

- 1) Remove camshaft cover(s). See CAMSHAFT COVER. Secure camshaft sprocket to timing chain using tie wraps through camshaft sprocket holes (2 tie wraps per sprocket).
- 2) Working behind sprockets, install Camshaft Chain Holder (J-38815) so it is positioned between chain tensioner and chain guide. See Fig. 5. Apply tension to holder by tightening tension adjusting screw.
- 3) Remove both camshaft sprocket bolts (note and mark location of camshaft drive pins in end of camshafts). Work sprockets off camshafts using play in chain.
- 4) Alternately loosen camshaft bearing cap screws a few turns at a time until all valve spring pressure has been released. Remove bolts and caps. Remove camshafts.

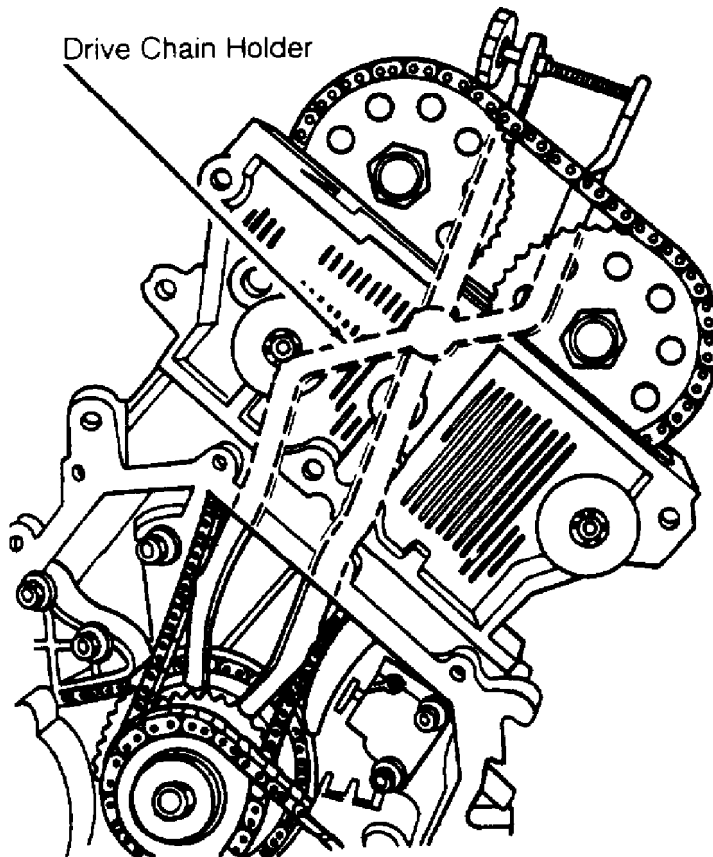

94A33696

Fig. 5: Installing Camshaft Chain Holder  
Courtesy of General Motors Corp.

### Inspection

Visually check lobes whenever a camshaft is removed. Excessive wear, scoring or flaking of lifter usually denotes camshaft lobe wear. Excessive camshaft lobe wear is evidenced by grooves, scoring or flaking. If any of these conditions exist, replace camshaft. Ensure bearing journals are not scored or burned.

**NOTE:** Each bearing cap is identified for position and direction. Arrow points to front of engine. "E" indicates exhaust camshaft. "I" indicates intake camshaft. Position No. 1 is toward front of engine.

### Installation

1) Apply Prelube (1052365) to face of each camshaft lobe. Position camshaft and bearing caps on head. Loosely install bearing cap bolts.

2) Alternately tighten bearing cap bolts a few turns at a time until all bolts are snug. Tighten bolts to specification. See TORQUE SPECIFICATIONS.

3) Use the hex that's cast into the camshaft to adjust camshafts until drive pins are in position to engage the camshaft sprockets over the camshafts, then start the retaining bolts. Refer to Fig. 6. Work the sprockets over the camshafts, and tighten the retaining bolts to specification. See TORQUE SPECIFICATIONS. To complete installation, reverse removal procedure.

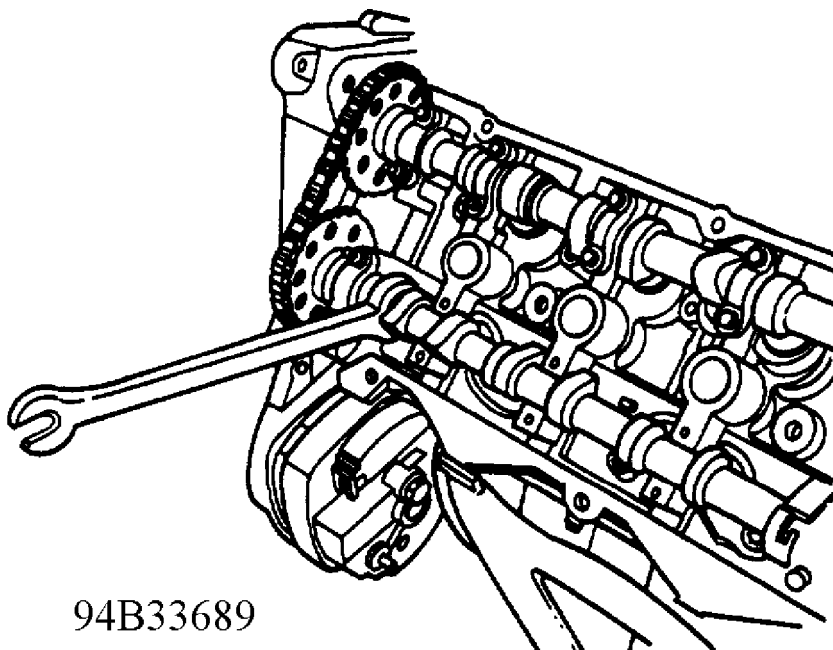

94B33689

Fig. 6: Adjusting Camshaft Position  
Courtesy of General Motors Corp.

system has been disturbed such that the relationship between any chain and sprocket has been lost. Even when only one sprocket is involved, the timing procedure should be observed since one crankshaft revolution will not confirm correct timing. The camshafts and crankshaft are correctly timed when the relationships shown in Fig. 7 exist (timing marks on crankshaft sprocket and intermediate shaft sprocket are aligned and all 4 camshaft drive pins are at a right angle to cylinder head surface).

#### Setting Camshaft Timing

1) Remove camshaft covers. See CAMSHAFT COVER. Remove front cover. See FRONT COVER. Remove or fully retract all 3 chain tensioners. Remove oil pump. See OIL PUMP under ENGINE OILING.

2) Primary and secondary chain guides should remain in place. Rotate crankshaft until sprocket drive key is positioned at about 1 o'clock.

3) Set crankshaft and intermediate shaft sprockets into primary drive chain with their timing marks adjacent to each other. See Fig. 7.

4) Install crankshaft and intermediate sprockets over their respective shafts. Rotate crankshaft as necessary to engage crankshaft key in sprocket without changing the timing mark relationship.

5) Install Flywheel Holder (J-39411) to lock crankshaft in position. If engine is on stand, an alternate locking method should be devised. Install intermediate sprocket retaining bolt and tighten to specification. See TORQUE SPECIFICATIONS.

6) Route secondary chain for left cylinder head over inner row of intermediate shaft teeth. Route secondary drive chain over chain guide, and install exhaust camshaft sprocket to chain so camshaft drive pin engages sprocket notch marked LE (left head exhaust). There should be no slack in lower section of chain, and camshaft drive pin must be perpendicular to cylinder head face. See Fig. 7.

7) Install intake camshaft sprocket into chain so the sprocket notch marked LI (left head intake) engages camshaft drive pin, while pin remains perpendicular to head face. Minor camshaft positioning adjustments can be made using open-end wrench on hex cast into camshaft. See Fig. 6.

8) Install sprocket retainer bolts and chain tensioner and tighten to specification. See TORQUE SPECIFICATIONS.

9) Route secondary chain for right cylinder head over outer row of intermediate shaft teeth, and repeat steps 6)

8). Right camshaft sprockets are identified RI (right intake) and RE (right exhaust). In addition, RE sprocket must contain camshaft position sensor pick-up.

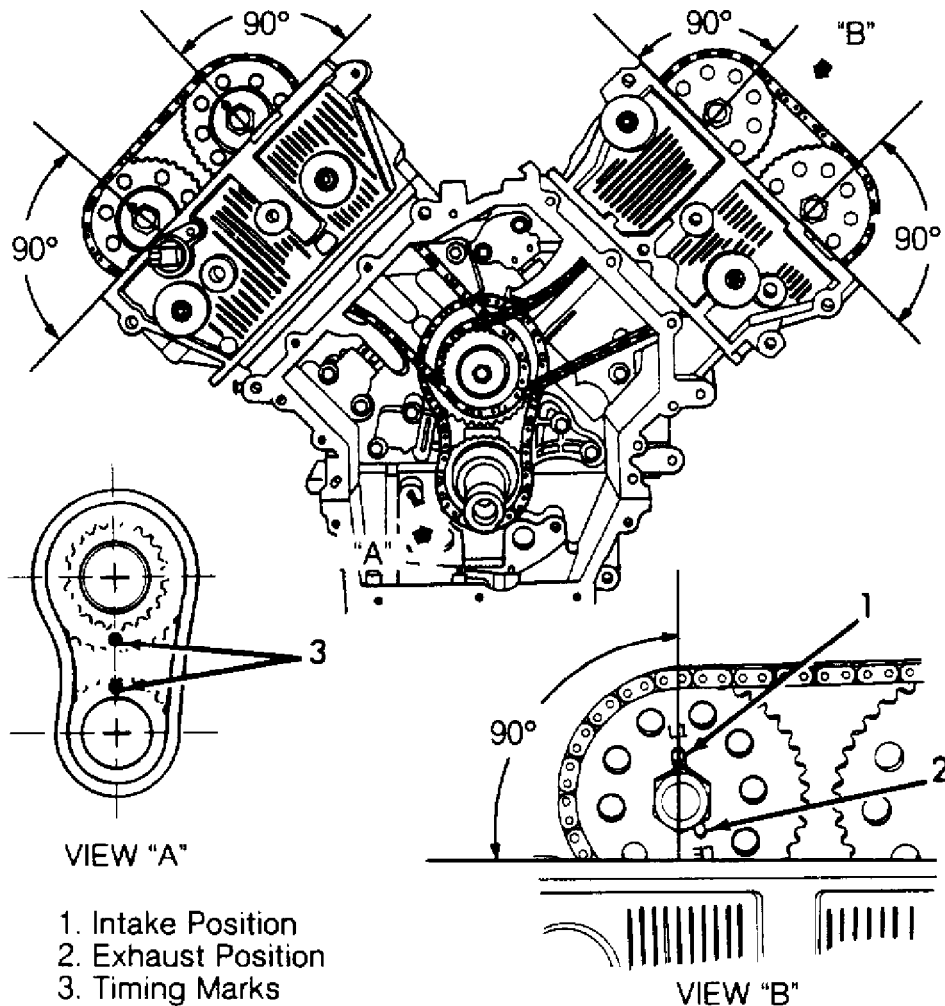

94B33697

Fig. 7: Setting Camshaft Timing  
Courtesy of General Motors Corp.

#### HARMONIC BALANCER

##### Removal

1) Release tension from accessory drive belt. Raise vehicle on hoist. Remove right front wheel. Remove 2 splash shields from wheelhouse. Remove brace between engine oil pan and transmission case, and install Flywheel Holder (J-39411). Remove balancer bolt.

2) Support engine cradle with tall screw jack, and remove 3 engine cradle bolts on right side of cradle. Disconnect Road Sensing Suspension (RSS) sensor from right lower control arm.

3) Lower engine cradle to obtain clearance below body rail for Puller (J-34816). Install pilot into end of crankshaft. Remove harmonic balancer using Puller (J-38416).

Position balancer on crankshaft and install using Installer (J-39344). Clean and oil balancer bolt threads and tighten to specification. See TORQUE SPECIFICATIONS. To complete installation, reverse removal procedure.

#### CRANKSHAFT MAIN BEARINGS

##### Removal

1) Remove engine and place on stand. See ENGINE. Remove oil pan, oil pump, oil pump pickup, oil baffle, main bearing bolts, oil manifold bolts, oil manifold and upper/lower crankcase bolts.

2) Working on either side of crankcase, separate crankcase halves by alternately prying in grooves provided until lower crankcase is free of dowel pins. Remove lower crankcase. See Fig. 8. Remove lower crankcase.

NOTE: Upper-to-lower crankcase seal may be reused unless it has been damaged or removed from its groove in upper crankcase.

3) Remove rear main seal and discard. Remove lower main bearings from lower crankcase. Remove upper main bearings by rolling out with aluminum pin inserted in oil hole of crank journal.

##### Installation

1) Install lower main bearing into lower crankcase. Install upper main bearing into upper crankcase. Ensure upper bearing has oil transfer hole. Roll bearing into position so lock tang engages crankcase slot. Bearing must fit flush with crankcase.

2) Inspect upper crankcase seal to ensure it is in position in crankcase. Seal must not be torn, nicked or out of groove over its entire length on both sides of crankcase.

3) Clean block groove. Start seal at both ends and work seal into groove toward center. Lower crankcase over dowels. Wiggle into installed position.

4) Install oil manifold. Install 20 main bearing bolts (inboard bolts have stud heads). Install 10 oil manifold bolts. Install 8 upper-to-lower crankcase bolts. See Fig. 9. Tighten bolts to specification. See TORQUE SPECIFICATIONS.

5) Check crankshaft end play. End play should not exceed .019" (.50 mm). Install oil baffle and 10 nuts. Tighten to specification. See TORQUE SPECIFICATIONS.

6) Install oil pump pick-up and NEW "O" ring. To complete installation, reverse removal procedure.

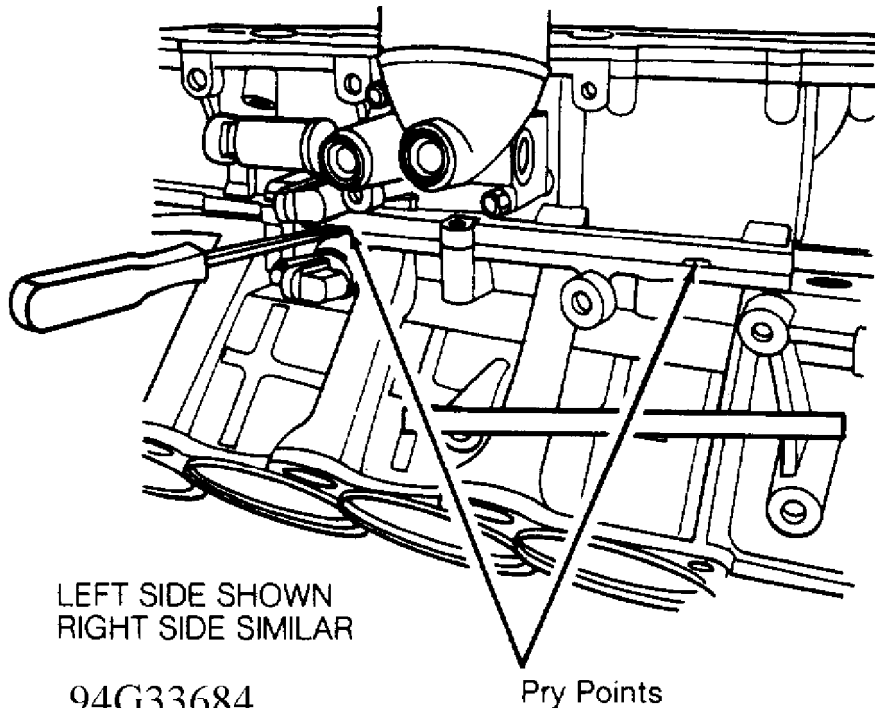

94G33684

Fig. 8: Separating Crankcase Halves  
Courtesy of General Motors Corp.

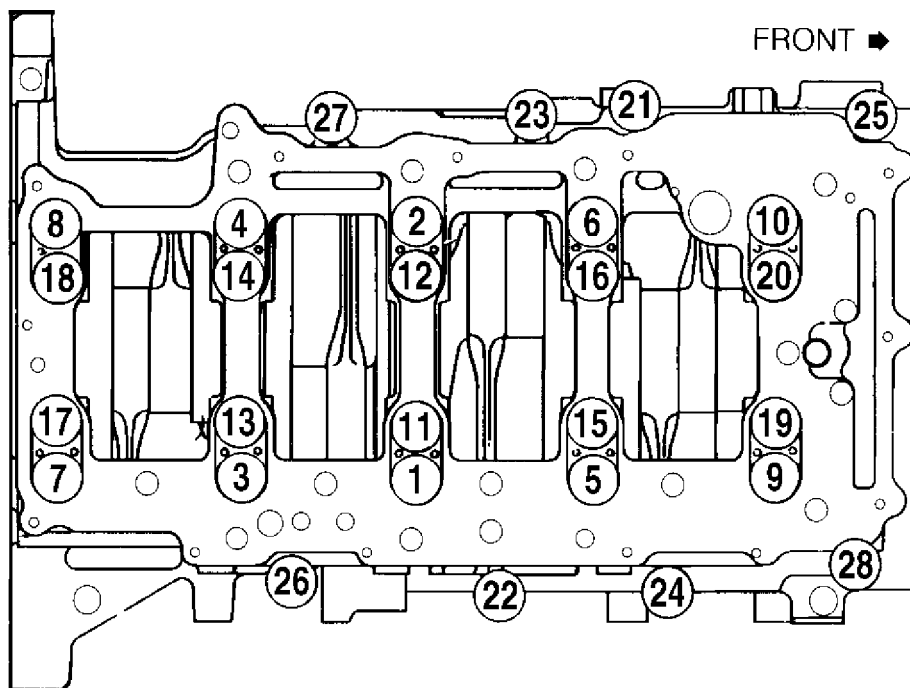

94H33685

Fig. 9: Tightening Main Bearings (Lower Crankcase)  
4.6L V8 - VIN [Article Text (p. 16)] 1995 Cadillac Concours For Ace Mechanics 123 Main Street San Diego Ca 92126Co  
Courtesy of General Motors Corp.

CRANKSHAFT REAR OIL SEAL

### Removal

1) Remove the transmission. Refer to the appropriate TRANSMISSION REMOVAL & INSTALLATION - A/T article in the TRANSMISSION SERVICING section. Remove flexplate.

2) Preferred method of seal removal is by drilling a 1/8" hole in metal seal body and removing with a body dent puller (slide hammer).

3) Seal removal with a screwdriver blade between seal lips and crankshaft is also possible, but extreme care is required to avoid damage to crankshaft sealing surface.

### Installation

1) Place a small dab of RTV sealant at crankcase split line between upper and lower cases. Lubricate seal lips with engine oil, and slide seal over arbor of Seal Installer (J-38817).

2) Thread seal installer into crankshaft flange, and install seal by turning handle until installer bottoms against crankshaft. To complete installation, reverse removal procedure.

## WATER PUMP

**NOTE:** Water Pump Remover/Installer (J-38816) is required to turn pump assembly.

### Removal

Drain cooling system. Remove air cleaner. Remove water pump cover (4 bolts). Remove water pump drive belt. Using Remover/Installer (J-38816), rotate water pump assembly clockwise and remove from vehicle. See Fig. 10.

### Installation

Clean water pump assembly and pump housing sealing surfaces. Using a NEW "O" ring, install water pump assembly and tighten counterclockwise to 74 ft. lbs. (100 N.m). To complete installation, reverse removal procedure. Tighten water pump cover bolts (4) to specification. See TORQUE SPECIFICATIONS.

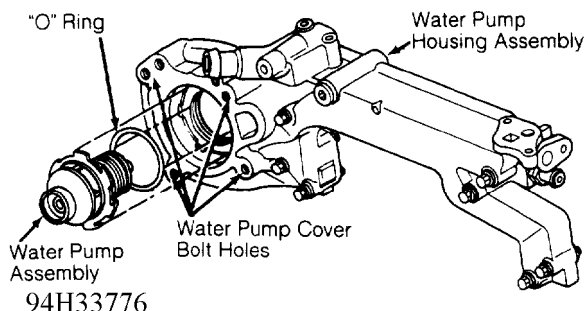

Fig. 10: Identifying Water Pump Assembly

Courtesy of General Motors Corp.

## OIL PAN

### Removal

Remove engine and place on stand. See ENGINE. Drain engine oil. Remove pan bolts and pan. Gasket is reusable unless damaged. DO NOT remove gasket from oil pan unless replacement is required.

### Installation

Install the new oil pan gasket, if required, by starting the seal into the pan groove and working the seal into the groove in both directions. Once the seal is exposed to oil, it will expand and no longer stay in the groove without wrinkles. If wrinkles exist, replace it with a NEW seal. See Fig. 11. To complete oil pan installation, reverse removal procedure. Tighten fasteners to specification. Refer to TORQUE SPECIFICATIONS.

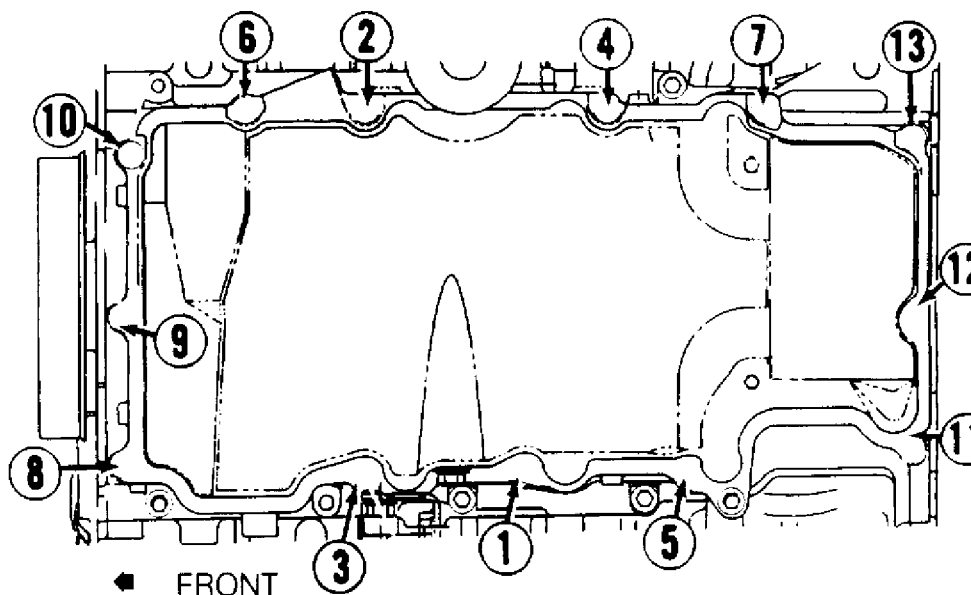

94C33698

Fig. 11: Tightening Oil Pan Bolts  
Courtesy of General Motors Corp.

## OVERHAUL

### CYLINDER HEAD

#### Cylinder Head Gasket Surface

If warpage exceeds specification, machine or replace cylinder head as necessary. See CYLINDER HEAD table under ENGINE SPECIFICATIONS. After machining, measure distance between gasket surface and gauge pad. See Fig. 12. If distance is less than .413" (10.50 mm), replace cylinder head.

### Valve Springs

Replace valve spring if free length and tension (pressure) are not within specification. See VALVES & VALVE SPRINGS table under ENGINE SPECIFICATIONS. If valve spring installed height is not as specified, put shim(s) under spring as necessary.

### Valve Stem Oil Seals

Install Lifter Bore Protector (J-38820-2). Using Remover/Installer (J-38820), grip valve stem seal. Twist and pull seal to remove it. Lubricate NEW seal with engine oil. Twist and push seal to install it.

### Valve Guides

1) Valve guides are not replaceable. Wear in the bottom .39" (10.0 mm) of valve guide is acceptable. Using a hole gauge, measure inside diameter of guide perpendicular (crosswise) to camshaft. Measure at top of bore and .39" (10.0 mm) from bottom of bore. Measure diameter of valve stem.

2) Subtract diameter of valve stem from greater of 2 valve guide inner diameter measurements. Resulting value is valve stem-to-guide oil clearance. If clearance exceeds specification, determine whether installing a NEW standard diameter valve stem will bring clearance within specification. If it will not, replace cylinder head. See CYLINDER HEAD table under ENGINE SPECIFICATIONS.

### Valve Seat

Valve seats are not replaceable.

### Valves

If head diameter, stem diameter or margin are not within specification, replace valve. See VALVES & VALVE SPRINGS table under ENGINE SPECIFICATIONS. DO NOT lap NEW valves, as protective coating will be damaged. Lightly lap used valves after they have been machined.

### Valve Seat Correction Angles

After grinding, if seat is too wide, use 20-degree and/or 65-degree stones to narrow the seat.

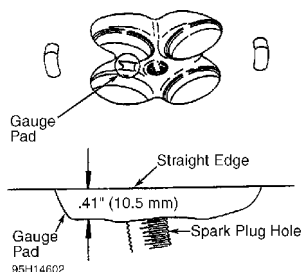

Fig. 12: Gauging Resurfaced Cylinder Head

## CYLINDER BLOCK ASSEMBLY

### Fitting Pistons

Measure piston diameter 1.81" (46 mm) below top of piston, at 90-degree angle to piston pin. Measure cylinder bore 2" (50 mm) below top of cylinder. If piston clearance is not to specification, replace piston. See PISTONS, PINS & RINGS table under ENGINE SPECIFICATIONS.

### Piston Rings

1) Each piston has 2 compression rings and a side-seal type oil ring that incorporates a steel expander and 2 identical chrome-plated steel rails. Top compression ring is molybdenum-filled steel. Second compression ring is coated cast iron.

2) When replacing piston rings, install only re-ring sets that have molybdenum-filled upper compression ring and multi-piece oil rings. Top compression ring may be installed with either side up. Second compression ring has a locating dimple identifying top side.

3) If piston ring end gap and side clearance are not within specification, replace rings and/or piston. See PISTONS, PINS & RINGS table under ENGINE SPECIFICATIONS. Ensure ring end gaps are correctly spaced around piston. See Fig. 13.

### Rod Bearings

Ensure the tangs on the bearings are positioned in the notches on the rod and cap before tightening the cap nuts. Measure the rod bearing oil clearance. Replace bearing if clearance exceeds specification. See CRANKSHAFT, MAIN & CONNECTING ROD BEARINGS table under ENGINE SPECIFICATIONS.

### Crankshaft & Main Bearings

Shell-type main bearings of steel-backed aluminum are used at all positions. Upper halves are interchangeable, as are the lower halves except for the bearings in No. 3 position (thrust bearing). To service main bearings, engine must be removed from vehicle. See CRANKSHAFT MAIN BEARINGS under REMOVAL & INSTALLATION.

### Thrust Bearing

1) To measure crankshaft end play, pry crankshaft to extreme forward position. Using feeler gauge, measure distance between crankshaft thrust face and thrust face of No. 3 bearing (front side of bearing).

2) When using a dial indicator, mount the indicator on a block beside the flywheel flange, and measure crankshaft movement while prying the crankshaft back and forth. If end play is not within specification, replace thrust bearing and/or crankshaft as necessary. See CRANKSHAFT, MAIN & CONNECTING ROD BEARINGS table under ENGINE SPECIFICATIONS.

### Cylinder Block Deck Surface

Deck warpage information is not available from manufacturer.

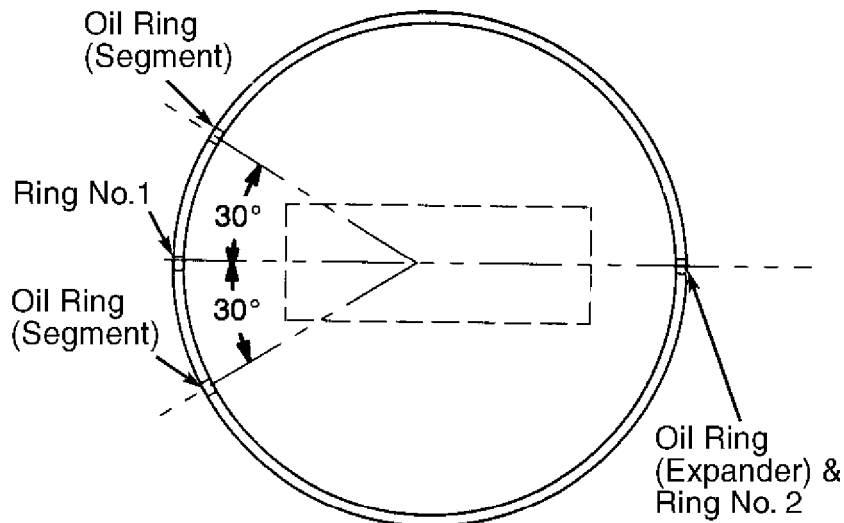

94D33699

Courtesy of General Motors Corp.

**Fig. 13: Positioning Piston Ring End Gaps**  
Courtesy of General Motors Corp.

## ENGINE OILING

### ENGINE LUBRICATION SYSTEM

Gerotor oil pump, mounted to lower crankcase behind front cover, is driven by clamp loading of the harmonic balancer bolt. See Figs. 13 and 14. Oil pump draws oil from sump through sump pick-up and cast channels. Pressurized oil enters lower crankcase distribution channel through pump outlet. Oil is routed through oil filter/cooler circuit to the engine.

#### Crankcase Capacity

Oil capacity is 7.5 qts. (7.0L) with filter.

#### Oil Pressure

Minimum oil pressure is 5 psi (.4 kg/cm<sup>2</sup>) at idle and 35 psi (2.5 kg/cm<sup>2</sup>) at 2000 RPM.

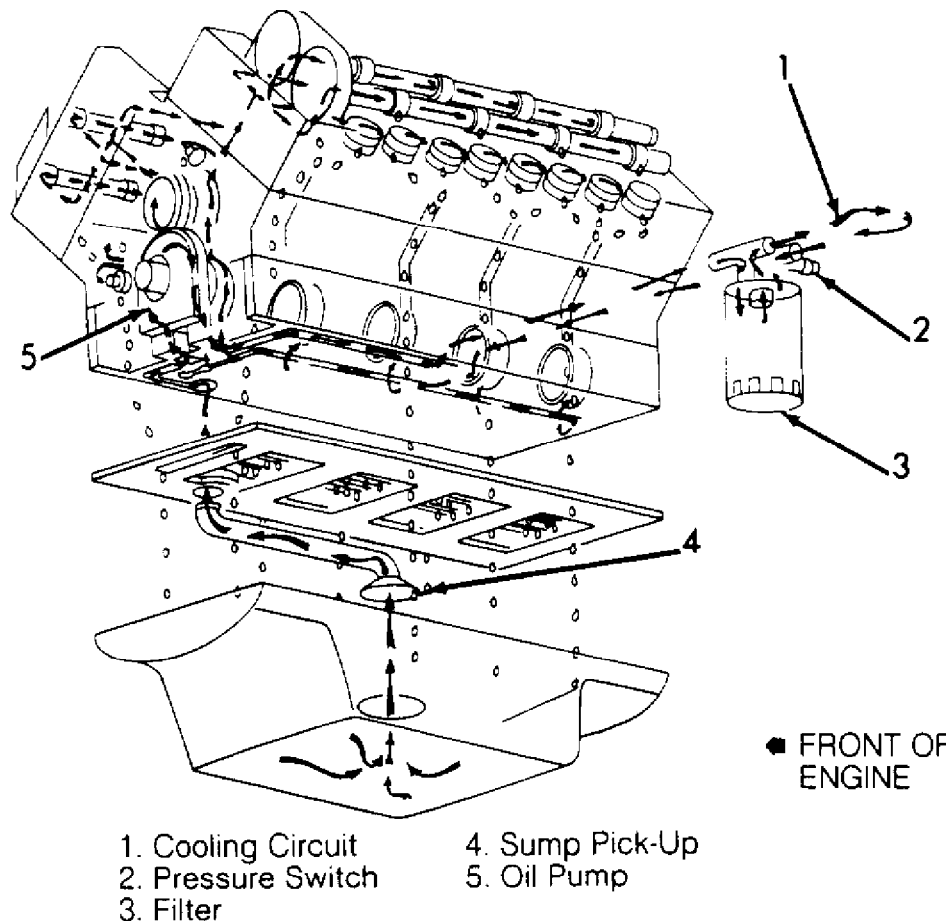

94C33706

Fig. 14: Cross-Sectional View Of Engine Oil Circuit  
Courtesy of General Motors Corp.

#### OIL PUMP

##### Removal & Disassembly

1) Remove front cover. See FRONT COVER under REMOVAL & INSTALLATION. Remove 3 oil pump mounting bolts. Remove pump and drive gear. See Fig. 15.

2) Remove drive spacer from pump housing. Remove 2 screws holding pump halves together. Remove inner (drive) and outer (driven) rotors from housing and mark for reassembly. Remove pressure relief valve. See Fig. 16.

4.6L V8 - VIN [Y]Article Text (p. 22)1995 Cadillac ConcoursFor Ace Mechanics 123 Main Street San Diego Ca 92126Cor  
Inspection

Inspect pump housing for nicks, burrs, chips or debris that might cause a leak or binding in rotor pocket. Inspect drive and driven rotors for nicks or burns. Check pump cover and interior surface for excessive wear or score marks. Check for flatness.

##### Reassembly & Installation

1) Lubricate rotors with engine oil and install in pump cover with same orientation as when removed. Install pressure relief valve seat, spring and pilot in pump housing.

2) Assemble housing and cover over locating dowel. Insert 3/8" (9.5 mm) drill bit into pump mounting hole, on side opposite dowel, to aid alignment of housing and cover. Install 2 screws and tighten to 106 INCH lbs. (12 N.m).

3) Install oil pump drive spacer into oil pump from rear so drive flat engages pump rotor. Position pump over crankshaft. Loosely install screws. Hold pump in its furthest up position while tightening screws. Tighten screws to specification. See TORQUE SPECIFICATIONS. To complete installation, reverse removal procedure.

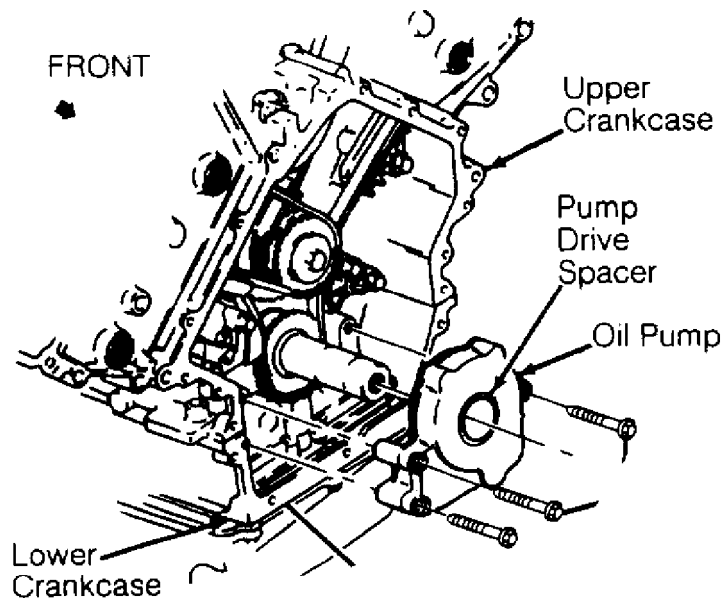

94G33700

Fig. 15: Removing & Installing Oil Pump  
Courtesy of General Motors Corp.

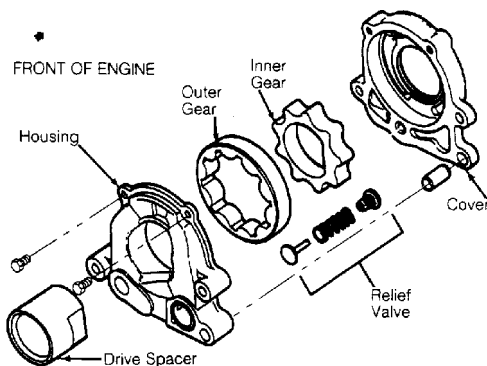

94H33701

Fig. 16: Exploded View Of Oil Pump  
Courtesy of General Motors Corp.

## TORQUE SPECIFICATIONS

### TORQUE SPECIFICATIONS

AAAAAAAAAAAAAAAAAAAAAAAAAAAAAAAAAAAAAAAAAAAAAAAAAAAAAAAAAAAAAAAAAAAAAAAA

Application	Ft. Lbs. (N.m)
Camshaft Chain Guide-To-Head Bolt .....	18 (25)
Camshaft Chain Tensioner-To-Block Bolt .....	18 (25)
Camshaft Sprocket Bolt .....	90 (120)
Connecting Rod Nut	
Step 1 .....	18 (25)
Step 2 .....	Additional 90 Degrees
Coolant Temperature Sensor .....	15 (20)
Crankshaft Balancer Bolt	
Step 1 .....	44 (60)
Step 2 .....	Additional 120 Degrees
Cylinder Head Bolt (1)	
Step 1 .....	22 (30)
Step 2 .....	Additional 60 Degrees
Step 3 .....	Additional 60 Degrees
Step 4 .....	Additional 60 Degrees (180° Total)
Drive Belt Idler Pulley Bolt .....	35 (50)
EGR Pipe-To-Water Outlet .....	20 (25)
EGR Tube-To-Intermediate Pipe Nut .....	45 (60)
EGR Valve .....	20 (25)
Engine Rear Mount Brace-To-Engine Bolt .....	76 (103)
Engine Rear Mount Strut Bracket Bolt .....	60 (82)
Exhaust Manifold Bolt/Nut .....	18 (25)
Flexplate Bolt	
Step 1 .....	11 (15)
Step 2 .....	Additional 50 Degrees
Intermediate Shaft Sprocket Bolt .....	45 (60)
Knock Sensor .....	15 (20)
Main Bearing Cap Bolt (2)	
Step 1 .....	15 (20)
Step 2 .....	Additional 65 Degrees
Oil Filter Adapter Bolt .....	20 (25)
Oil Filter Adapter Plug .....	35 (50)
Oil Level Sensor .....	25 (30)
Oil Pan Baffle Nut .....	18 (25)
Oil Pan Drain Plug .....	15 (20)
Oil Pump Drive Assembly Bolt .....	27 (36)
Oxygen Sensor .....	30 (40)
Starter-To-Block Bolt .....	25 (30)
Timing Belt Pulley & Bracket Bolt .....	37 (50)
Timing Chain Tensioner Bolt .....	35 (50)
Torque Converter-To-Flywheel Bolt .....	45 (60)
Valve Adjuster (p. 24) .....	25 (30)

Torque Strut Bracket-To-Water Manifold Bolt	.....	20 (25)
Transmission-To-Engine Bolt		
Short	.....	35 (50)
Long	.....	55 (75)
Transmission Brace-To-Block Bolt	.....	35 (50)
Transmission Brace-To-Oil Pan Bolt	.....	35 (50)
Transmission Brace-To-Transmission Bolt	.....	35 (50)
Water Outlet-To-Head Bolt	.....	20 (25)
Water Pump Housing To Block Bolt	.....	20 (25)
Water Pump Housing To Head bolt	.....	20 (25)

		INCH Lbs. (N.m)
Camshaft Bearing Cap Bolt	.....	106 (12)
Camshaft Cover Bolt	.....	89 (10)
Camshaft Seal-To-Cover Bolt	.....	10 (1.1)
Camshaft Thrust/Retaining Plate Bolt	.....	89 (10)
Coolant Drain Plug	.....	71 (8)
Crankshaft Position Sensor	.....	89 (10)
Flexplate Housing Cover Bolt	.....	106 (12)
Front Cover Bolt	.....	98 (10)
Ignition Module-To-Camshaft Cover Bolt	.....	106 (12)
Intake Manifold Bolt	.....	89 (10)
Oil Dipstick Tube Bolt	.....	89 (10)
Oil Manifold-To-Lower Crankcase Bolt	.....	89 (10)
Oil Pan Bolt (3)	.....	89 (10)
Oil Pump Suction Pipe Bolt	.....	89 (10)
Oil Pump-To-Lower Crankcase Bolt		
Step 1	.....	89 (10)
Step 2	.....	Additional 35 Degrees
Tensioner-To-Water Manifold Stud	.....	89 (10)
Thermostat Housing-To-Water Pump Housing Bolt	....	89 (10)
Water Pump Cover Bolt	.....	89 (10)

- (1) - Tighten in sequence. See Fig. 1.
- (2) - Tighten in sequence. See Fig. 9.
- (3) - Tighten in sequence. See Fig. 11.

AAAAAAAAAAAAAAAAAAAAAAAAAAAAAAAAAAAAAAAAAAAAAAAAAAAAAAAAAAAAAAAAAAAAAAAA

**ENGINE SPECIFICATIONS**

GENERAL SPECIFICATIONS

GENERAL SPECIFICATIONS

AAAAAAAAAAAAAAAAAAAAAAAAAAAAAAAAAAAAAAAAAAAAAAAAAAAAAAAAAAAAAAAAAAAAAAAA

Application	Specification
Displacement	279 Cu. In. (4.6L)
Bore	3.66" (93.0 mm) 4.6L V8 - VIN [Y]Article

Stroke ..... 3.31" (84.0 mm)  
 Compression Ratio ..... 10.3:1  
 Fuel System ..... SFI  
 Horsepower @ RPM (1) ..... 270 @ 5600  
 Torque Ft. Lbs. @ RPM (1) ..... 300 @ 4000

(1) - Difference between VIN Y engine and VIN 9 engine is the profile of the intake camshaft lobes (alters horsepower and torque curve).

AAAAAAAAAAAAAAAAAAAAAAAAAAAAAAAAAAAAAAAAAAAAAAAAAAAAAAAAAAAAAAAAAAAAAAAA

CRANKSHAFT, MAIN & CONNECTING ROD BEARINGS

CRANKSHAFT, MAIN & CONNECTING ROD BEARINGS

AAAAAAAAAAAAAAAAAAAAAAAAAAAAAAAAAAAAAAAAAAAAAAAAAAAAAAAAAAAAAAAAAAAAAAAA

Application In. (mm)

Crankshaft End Play ..... .002-.020 (.05-.50)

Main Bearings

Journal Diameter ..... 2.5338 (64.358)

Journal Maximum Out-Of-Round ..... .0005 (.013)

Journal Maximum Taper ..... .0005 (.013)

Oil Clearance

Standard ..... .0006-.0022 (.015-.055)

Wear Limit ..... .0030 (.070)

Connecting Rod Bearings

Journal Diameter ..... 2.1258 (53.955)

Journal Out-Of-Round ..... .0005 (.013)

Journal Taper ..... .0005 (.013)

Oil Clearance ..... .0010-.0030 (.025-.076)

AAAAAAAAAAAAAAAAAAAAAAAAAAAAAAAAAAAAAAAAAAAAAAAAAAAAAAAAAAAAAAAAAAAAAAAA

CONNECTING RODS

CONNECTING RODS

AAAAAAAAAAAAAAAAAAAAAAAAAAAAAAAAAAAAAAAAAAAAAAAAAAAAAAAAAAAAAAAAAAAAAAAA

Application In. (mm)

Bore Diameter

Crankpin Bore (W/O Bearing) ..... 2.2498 (57.144)

Piston Pin Bore ..... .8662-.8665 (22.002-22.008)

Center-To-Center Length ..... 5.945 (151.00)

Side Play ..... .008-.020 (.20-.50)

AAAAAAAAAAAAAAAAAAAAAAAAAAAAAAAAAAAAAAAAAAAAAAAAAAAAAAAAAAAAAAAAAAAAAAAA

PISTONS, PINS & RINGS

PISTONS, PINS & RINGS

AAAAAAAAAAAAAAAAAAAAAAAAAAAAAAAAAAAAAAAAAAAAAAAAAAAAAAAAAAAAAAAAAAAAAAAA

Application In. (mm)

Pistons

Clearance ..... .0004-.0020 (.010-.050)
Pin Bore ..... .8662-.8665 (22.002-22.008)

Pins (1)

Diameter ..... .8659-.8661 (21.995-22.000)

Rings

No. 1

End Gap ..... .010-.016 (.25-.40)
Side Clearance ..... .0016-.0037 (.040-.095)

No. 2

End Gap ..... .014-.020 (.35-.50)
Side Clearance ..... .0016-.0037 (.040-.095)

No. 3 (Oil)

End Gap ..... .010-.030 (.25-.76)
Side Clearance ..... None (Side-Sealing)

(1) - Pins are retained with snap rings.

AAAAAAAAAAAAAAAAAAAAAAAAAAAAAAAAAAAAAAAAAAAAAAAAAAAAAAAAAAAAAAAAAAAAAAAA

CYLINDER BLOCK

CYLINDER BLOCK

AAAAAAAAAAAAAAAAAAAAAAAAAAAAAAAAAAAAAAAAAAAAAAAAAAAAAAAAAAAAAAAAAAAAAAAA

Application In. (mm)

Cylinder Bore Diameter ..... 3.6614 (93.000)
Cylinder Bore Maximum Out-Of-Round ..... .0008 (.020)
Cylinder Bore Maximum Taper ..... .0004 (.010)
Maximum Deck Warpage ..... (1)
Deck Height ..... (1)

(1) - Information is not available from manufacturer.

AAAAAAAAAAAAAAAAAAAAAAAAAAAAAAAAAAAAAAAAAAAAAAAAAAAAAAAAAAAAAAAAAAAAAAAA

VALVES & VALVE SPRINGS

VALVES & VALVE SPRINGS

AAAAAAAAAAAAAAAAAAAAAAAAAAAAAAAAAAAAAAAAAAAAAAAAAAAAAAAAAAAAAAAAAAAAAAAA

Application In. (mm)

Valves

Intake

Face Angle ..... 45ø
Head Diameter ..... 1.22" (31.0 mm)

Minimum Margin ..... .005" (.13 mm)  
 Length ..... 4.169" (105.89 mm)  
 Stem Diameter ..... .2331-.2339" (5.9207-5.9411 mm)  
 Installed Height  
 Spring Seat Installed  
     Standard ..... 1.390-1.454" (35.30-36.92 mm)  
     Wear Limit ..... 1.463" (37.17 mm)  
 Spring Seat NOT Installed  
     Standard ..... 1.435-1.490" (36.46-37.85 mm)  
     Wear Limit ..... 1.501" (38.13 mm)

**Exhaust**

Face Angle ..... 45°  
 Head Diameter ..... 1.14" (29.0 mm)  
 Minimum Margin ..... .030" (.76 mm)  
 Length ..... 3.564" (90.53 mm)  
 Stem Diameter ..... .2331-.2339" (5.9207-5.9411 mm)  
 Installed Height  
 Spring Seat Installed  
     Standard ..... 1.333-1.393" (33.85-35.38 mm)  
     Wear Limit ..... 1.403" (35.63 mm)  
 Spring Seat NOT Installed  
     Standard ..... 1.380-1.432" (35.05-36.37 mm)  
     Wear Limit ..... 1.442" (36.62 mm)

**Valve Springs**

Free Length ..... 1.591" (40.40 mm)  
 Installed Height ..... 1.193" (30.30 mm)

Lbs. @ In. (kg @ mm)

**Pressure**

Valve Closed ..... 53 @ 1.19 (24 @ 30.3)  
 Valve Open ..... 109 @ .82 (49 @ 20.9)

AAAAAAAAAAAAAAAAAAAAAAAAAAAAAAAAAAAAAAAAAAAAAAAAAAAAAAAAAAAAAAAAAAAAAAAA

**CYLINDER HEAD**

**CYLINDER HEAD**

AAAAAAAAAAAAAAAAAAAAAAAAAAAAAAAAAAAAAAAAAAAAAAAAAAAAAAAAAAAAAAAAAAAAAAAA

Application Specification

Deck Warpage ..... (1)

**Valve Seats**

Intake Valve  
     Seat Angle ..... 46°  
     Seat Width ..... .030" (.76 mm)  
     Maximum Seat Runout ..... .002" (.05 mm)

Exhaust Valve

Seat Angle ..... 46ø  
 Seat Width ..... .035" (.90 mm)  
 Maximum Seat Runout ..... .002" (.05 mm)

Valve Guides

Valve Guide Inner Diameter ..... .2354" (5.979 mm)  
 Valve Stem-To-Guide Oil Clearance

Standard

Intake ..... .001-.003" (.03-.07 mm)  
 Exhaust ..... .002-.004" (.05-.10 mm)

Wear Limit ..... .005 (.12)

(1) - If warpage is less than .002" (.05 mm), it is not necessary to resurface cylinder head. If warpage is .002-.008" (.05-.20 mm), resurface cylinder head. After resurfacing, measure distance between gasket surface and gauge pad. See Fig. 12. If distance is less than .413" (10.50 mm), replace cylinder head.

AAAAAAAAAAAAAAAAAAAAAAAAAAAAAAAAAAAAAAAAAAAAAAAAAAAAAAAAAAAAAAAAAAAAAAAA

CAMSHAFT

CAMSHAFT

AAAAAAAAAAAAAAAAAAAAAAAAAAAAAAAAAAAAAAAAAAAAAAAAAAAAAAAAAAAAAAAAAAAAAAAA

Application In. (mm)

Bearing Bore Diameter ..... 1.0639 (27.023)

Journal Diameter ..... 1.0609-1.0619 (26.948-26.972)

Lobe Lift ..... .339 (8.60)

Oil Clearance

Standard ..... .002-.003 (.05-.08)

Wear Limit ..... .006 (.15)

AAAAAAAAAAAAAAAAAAAAAAAAAAAAAAAAAAAAAAAAAAAAAAAAAAAAAAAAAAAAAAAAAAAAAAAA

VALVE LIFTERS

VALVE LIFTERS

AAAAAAAAAAAAAAAAAAAAAAAAAAAAAAAAAAAAAAAAAAAAAAAAAAAAAAAAAAAAAAAAAAAAAAAA

Application In. (mm)

Lifter Diameter ..... 1.297-1.298 (32.959-32.975)

Bore Diameter ..... 1.299 (33.000)

Oil Clearance ..... .0010-.0030 (.025-.066)

AAAAAAAAAAAAAAAAAAAAAAAAAAAAAAAAAAAAAAAAAAAAAAAAAAAAAAAAAAAAAAAAAAAAAAAA

END OF ARTICLE