

F - BASIC TESTING

Article Text

1995 Cadillac Concours

For Ace Mechanics 123 Main Street San Diego Ca 92126

Copyright © 1997 Mitchell International

Friday, November 28, 2003 07:15PM

ARTICLE BEGINNING

1995 ENGINE PERFORMANCE

General Motors Corp. Basic Diagnostic Procedures

Cadillac; Concours, DeVille, Seville

INTRODUCTION

The following diagnostic steps will help prevent overlooking a simple problem. This is also where to begin diagnosis for a no-start condition.

The first step in diagnosing any driveability problem is verifying the customer's complaint with a test drive under the conditions during which the problem reportedly occurred.

Before entering self-diagnostics, perform a careful and complete visual inspection. Most engine control problems result from mechanical breakdowns, poor electrical connections or damaged/misrouted vacuum hoses. Before condemning the computerized system, perform each test listed in this article.

The following table provides the location of commonly used diagnostic information. These former "A" and "C" charts are now written in text and inserted into the appropriate location in the new Engine Performance workflow. To familiarize yourself with the Engine Performance workflow, see HOW TO USE THE ENGINE PERFORMANCE SECTION article in GENERAL INFORMATION section.

GENERAL MOTORS A & C CHART REFERENCE TABLE

AA
System or Component Diagnostic Information Location

A-1 & A-2, Malfunction Indicator

Light (MIL)	See DIAGNOSTIC CIRCUIT CHECK
A-3, No Start	See NO START - ENGINE CRANKS OKAY
A-5, Fuel Pump Relay	(1) See RELAYS, SOLENOIDS & MOTORS
A-7, Fuel System Diagnosis	See BASIC FUEL SYSTEM CHECKS
C-1, ECM/PCM Replacement Check	See ECM/PCM REPLACEMENT CHECK
C-1, MAP Sensor	(1) See ENGINE SENSORS & SWITCHES
C-1, Power Steering Pressure Switch	(1) See ENGINE SENSORS & SWITCHES
C-1, Park/Neutral Switch	(1) See ENGINE SENSORS & SWITCHES
C-2, Injector Balance Test	(1) See FUEL SYSTEM
C-2, Injector Leak Test	(1) See FUEL SYSTEM
C-2, IAC Motor	(1) See IDLE CONTROL SYSTEM in
C-2, ISC Motor	(1) See IDLE CONTROL SYSTEM in
C-3, Canister Purge System (Fuel Evaporation Control)	(1) See EMISSION SYSTEMS & SUB-SYSTEMS

- C-4, EST Ignition Check See BASIC IGNITION SYSTEM CHECKS
- C-5, KS Ignition Check (1) See IGNITION SYSTEM
- C-6, Air Injection System (1) See EMISSION SYSTEMS & SUB-SYSTEMS
- C-7, EGR System (1) See EMISSION SYSTEMS & SUB-SYSTEMS
- C-8, Manual Transmission
 - Shift Lights (Trans.) (1)(2) See MISCELLANEOUS ECM CONTROLS
- C-8, Torque Converter
 - Clutch (Transmission) (1) See MISCELLANEOUS ECM CONTROLS
- C-10, A/C Clutch Control (1)(3) See MISCELLANEOUS ECM CONTROLS
- C-12, Electric Cooling
 - Fan Control (1) (3) See MISCELLANEOUS ECM CONTROLS
- C-16, Engine Coolant Level Switch See ENGINE SENSORS & SWITCHES
- C-16, Fuel Pump/Oil
 - Pressure Switch See ENGINE SENSORS & SWITCHES
- C-16, Oil Level Switch See ENGINE SENSORS & SWITCHES

- (1) - Refer to I - SYSTEM/COMPONENT TESTS article in the ENGINE PERFORMANCE section.
 - (2) - Covered in entirety in the TRANSMISSION SERVICE & REPAIR section.
 - (3) - Covered in entirety in the ENGINE COOLING section.
- AA

NOTE: Perform all voltage tests with a Digital Volt-Ohmmeter (DVOM) with a minimum 10-megohm input impedance, unless stated otherwise in test procedure.

PRELIMINARY INSPECTION & ADJUSTMENTS

VISUAL INSPECTION

Visually inspect all electrical wiring, looking for chafed, stretched, cut or pinched wiring. Ensure electrical connectors fit tightly and are not corroded. Ensure vacuum hoses are properly routed and not pinched or cut. See M - VACUUM DIAGRAMS article in the ENGINE PERFORMANCE section to verify routing and connections (if necessary). Inspect air induction system for possible vacuum leaks.

MECHANICAL INSPECTION

Compression

Check engine mechanical condition with a compression gauge, vacuum gauge, or an engine analyzer. See engine analyzer manual for specific instructions. For compression specifications, see C - SERVICE & ADJUSTMENT SPECIFICATIONS article in the ENGINE PERFORMANCE section.

WARNING: DO NOT use ignition switch during compression tests on fuel

injected vehicles. Use a remote starter to crank engine. Fuel injectors on many models are triggered by ignition switch during cranking mode, which can create a fire hazard or contaminate engine oiling system.

Exhaust System Backpressure

Before replacing any components, check exhaust system for restrictions. The exhaust system can be checked with a vacuum gauge or a low pressure (0-5 psi) pressure gauge.

If a vacuum gauge is used, connect vacuum gauge hose to intake manifold vacuum port and start engine. Observe vacuum gauge. Open throttle part way and hold steady. If vacuum gauge reading slowly drops after stabilizing, exhaust system should be checked for a restriction. If using a low pressure gauge, connect gauge in one of the following manners:

* Check At AIR Pipe

Remove rubber hose at exhaust manifold AIR pipe check valve and remove check valve. Install pressure gauge to hose and nipple via Propane Enrichment Device(J-26911). Nipple should be inserted into exhaust manifold AIR pipe.

* Check At Oxygen Sensor

Remove oxygen sensor. Install backpressure tester in place of oxygen sensor. After test is completed, coat oxygen sensor threads with anti-seize compound.

Diagnosis

1) Start engine and bring to operating temperature. Increase engine speed to 2000-2500 RPM and note gauge. Reading should not exceed 1.25 psi (.09 kg/cm²). Exhaust system is restricted if specification is exceeded.

2) Check exhaust system for collapsed pipe, heat distress and possible internal muffler failure. If none of these conditions exist, check for restricted catalytic converter. Replace as required.

PCM REPLACEMENT CHECK

Many test procedures and test charts in ENGINE PERFORMANCE lead to conclusion that PCM is faulty. Before replacing PCM, check driven circuits and PCM Quad-Drivers (QDR) using following procedures and accompanying flow chart. See QDR Check Flow Chart below.

1) Using a DVOM, backprobe PCM drive circuit in question and measure pin voltage with ignition on. If system voltage is present, go to next step. If system voltage is not present, turn ignition off. Disconnect PCM connector. Measure voltage on connector terminal for F-BASIC T

3 QDR Failure. 3 3 Tested Above. 3
 3* Disconnect The Component In That 3 3 Measure Sustained 3
 3 Vehicle Circuit And Check For A Short 3 3 Current Flow Through 3
 3 To Voltage. If The Circuit Is Not 3 3 Each Circuit For 2 3
 3 Shorted To Voltage, Replace The 3 3 Minutes Each (In Most 3
 3 Component In That Circuit And The ECM. 3 3 Cases, The TCC Sol. 3
 3* Note Amperage. 3
 3 Draw). 3
 3 If Circuit(s) Has More Than 3 3* Note Amperage. 3
 3 0.75 Amps Current Draw. EGR 3 3 3
 3 Solenoids Tend To Draw About 3 3 3
 3 1.2 Amps. 3 3 3
 3* Check For Voltage Short To 3 3 3
 3 Voltage In Excessive 3 3 3
 3 Draw Circuit. 3 3 3
 3* If No Short To Voltage, 3 3 3
 3 Replace Related Solenoid Or 3 3 3
 3 Relay. 3 3 3
 3* Replace ECM. 3
 3 3

NO START DIAGNOSIS (A-3)

NOTE: Some vehicles are equipped with anti-theft systems (VATS or PASS-Key(R)) which will not allow vehicle to be started if improper starting procedures or improperly coded ignition keys are used. Both fuel injection and cranking systems will be disabled. Loss of fuel enable signal from anti-theft decoder module should set a trouble code in PCM memory.

Definition

No start is defined as engine cranks properly, but does not start. Engine may fire a few times.

NO START - ENGINE CRANKS OK (4.9L W/ HEI DIST)

NOTE: Check battery condition, engine cranking speed and fuel supply before performing the following tests.

General Inspection

- 1) Ensure proper starting procedure is being used.
- 2) Visually check vacuum hoses for splits, kinks and proper connections, as shown on underhood Vehicle Emission Control Information label. Check ignition wires for cracking, hardness and

proper connections at both distributor cap and spark plugs.

3) Remove spark plugs. Check and replace as necessary. Remove distributor cap and check for moisture, dust, cracks, burns and arcing to ground through coil mounting screws or rotor.

4) Try to turn distributor shaft by hand. Drive gear pin may be broken. In very cold temperatures, ensure oil is of proper viscosity and not contaminated with gasoline.

Ignition System

1) Disconnect White tachometer wire at distributor TACH (C-) terminal (if equipped). A shorted tachometer or tachometer circuit will prevent vehicle from starting.

2) Connect Spark Tester (ST-125) to end of one plug wire and crank engine. If spark occurs, check spark plugs and fuel delivery.

3) If spark does not occur, check a second wire. If no spark occurs, check voltage at BAT terminal at distributor while cranking engine. If reading is less than 7 volts, repair open circuit between BAT terminal and ignition switch.

4) If reading is greater than 7 volts, check voltage on TACH terminal with ignition on, engine off. If reading is 1-10 volts, replace module. Fabricate an HEI coil spark tester by trimming a spark plug boot and connecting it to Spark Tester (ST-125). See Fig. 1. Crank engine. If spark occurs, system is okay. If no spark occurs, replace ignition coil.

5) If reading at TACH terminal is less than one volt, repair faulty ignition coil connection or replace faulty ignition coil.

6) If voltage reading at TACH terminal of distributor is greater than 9.9 volts, remove and invert distributor cap with wires connected. Fabricate an HEI coil spark tester by trimming a spark plug boot and connecting it to Spark Tester (ST-125). See Fig. 1. Crank engine.

7) If spark occurs, check cap for cracks, water or other defects. Verify correct pick-up coil is used. Proper pick-up coil has a Black connector.

8) If spark does not occur, turn ignition off and disconnect pick-up coil leads from module. Turn ignition on. With voltmeter connected to distributor TACH terminal and fabricated coil spark tester connected, momentarily touch test light, connected to battery voltage, to ignition module terminal "P". See Fig. 2.

9) If voltage at TACH terminal does not drop, check ignition module ground and for open in wires from ignition coil to module. If all is okay, replace ignition module.

10) If voltage at TACH terminal drops, check for spark at spark tester as test light is removed from terminal "P". If spark does not occur, go to next step. If spark occurs, check distributor grounds for open circuits. Repair as necessary. If no open circuits are present, check pick-up coil connections and for 500-1500 ohms resistance at pick-up coil leads. Repair as necessary.

11) If spark does not occur, test ignition module with module tester. If module tests okay, check ignition coil wire. If module tester is not available, replace ignition coil and again touch terminal "P." If spark occurs, system is okay. If spark does not occur, reinstall original ignition coil and replace ignition module.

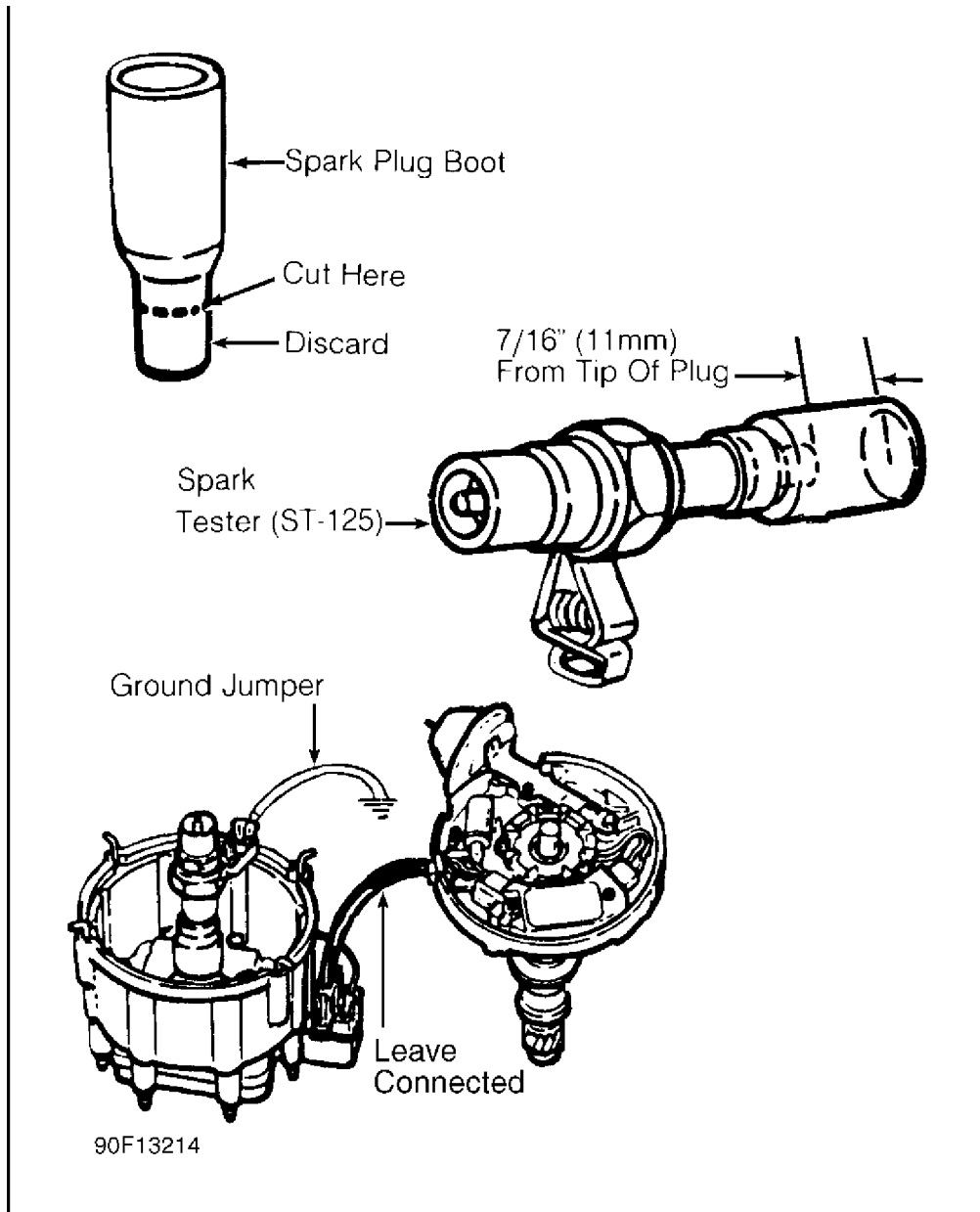

Fig. 1: Checking HEI Distributor Coil Spark (4.9L Cadillac)
Courtesy of General Motors Corp.

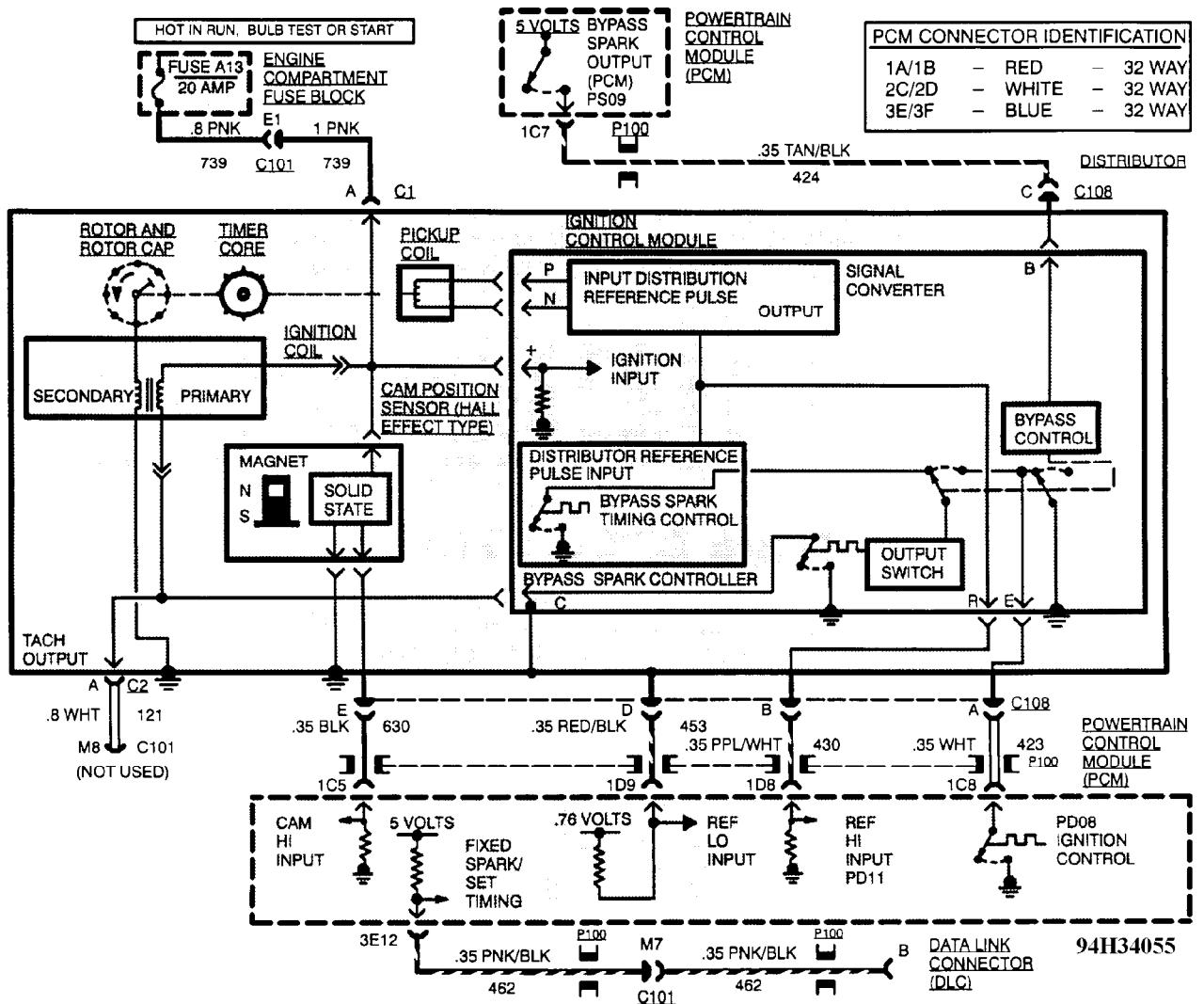

Fig. 2: 4.9L Ignition System (Cadillac)
 Courtesy of General Motors Corp.

Fuel System

1) Prior to checking fuel system for a no-start condition, check ignition for proper spark. Check for proper fuel pump pressure and capacity. See BASIC FUEL SYSTEM CHECKS.

2) Disconnect injector harness. Turn ignition on and check for battery voltage at each injector harness. See Fig. 3. Battery voltage should be present on one side of each injector connector. If battery voltage is not present, check for blown injector power fuse. If battery voltage is present on both injector terminals, check for wires shorted together.

F - BASIC TESTING Article Text (p. 8) 1995 Cadillac Corsica For A only and 1995 Cadillac San Diego Ca 92126 connect injector test light to injector harness. Crank engine and note test light. Repeat on other injector connectors. If test light flashes, check for stored PCM codes. If no codes are present, refer to HARD START symptom in H - TROUBLE SHOOTING - NO CODES article in the

ENGINE PERFORMANCE section.

4) If test light does not flash, disconnect distributor 5-wire connector. Momentarily touch test light from battery voltage to PCM RPM reference wire (Purple/White wire) of 5-wire connector. Each time test light is removed from PCM RPM reference terminal, injector test light should flash. If test light does not flash, check for open in RPM reference wire or injector drive (ground) circuit or replace faulty PCM.

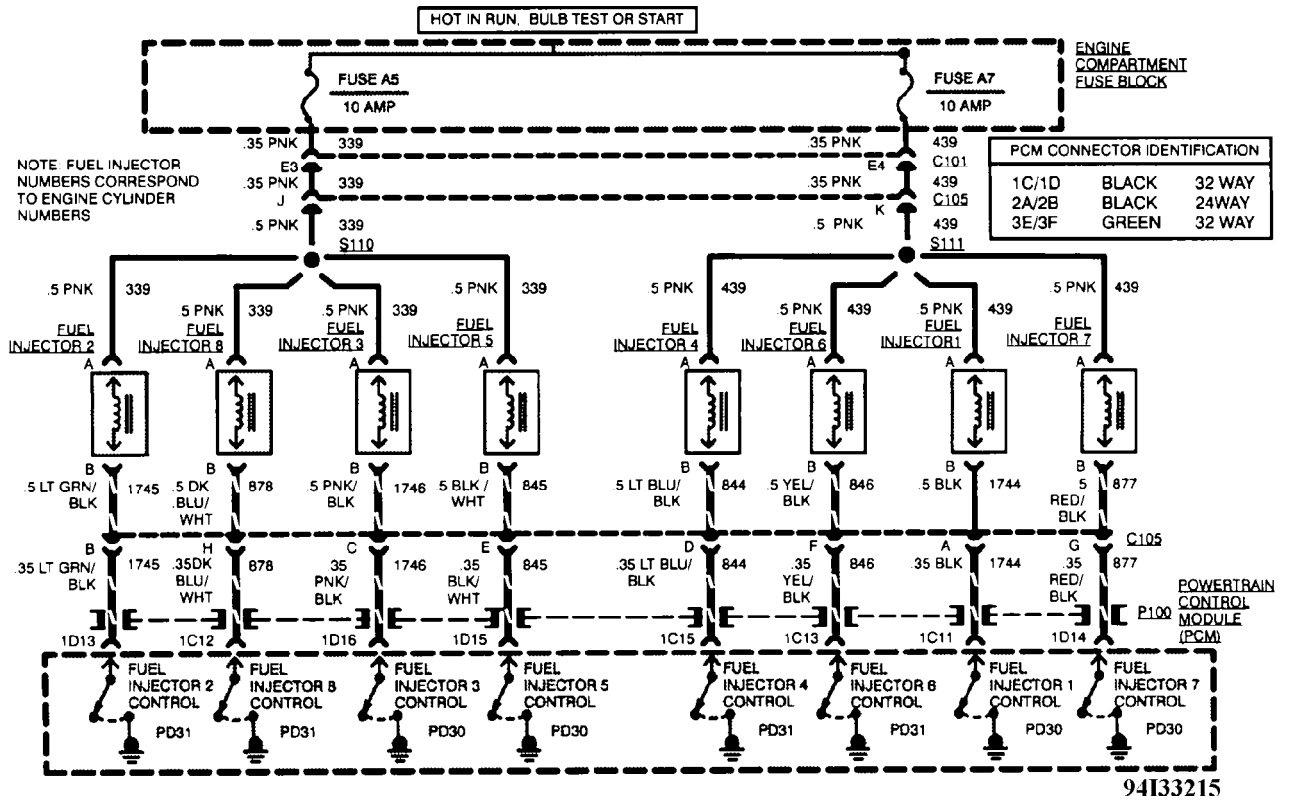

Fig. 3: 4.9L Injector System Schematic (Cadillac)
 Courtesy of General Motors Corp.

NO START - ENGINE CRANKS OKAY (4.6L WITH DIS)

NOTE: Ensure battery is fully charged and check engine cranking speed and fuel supply before performing following tests.

General Inspection

1) Ensure proper starting procedure is being used. Visually check vacuum hoses for splits, kinks and proper connections, as shown on Vehicle Emission Control Information label. Check ignition wires for cracking, hardness and proper connections at both coil pack and spark plugs.

2) Remove spark plugs. Check and replace as necessary. In very cold temperatures, ensure oil is of proper viscosity and not contaminated with gasoline.

Ignition System

1) Enter self-diagnostics. Diagnose any PCM trouble code present first. See G - TESTS W/CODES article in the ENGINE PERFORMANCE section. If trouble codes are not present, start engine. If engine does not start or is hard to start, go to next step.

2) Disconnect Ignition Control Module (ICM) C3 connector. Using DVOM, backprobe circuit No. 739 (Pink wire) to ICM terminal "C". See Fig. 4. If less than battery voltage is present, check circuit No. 739 (Pink wire) or fuse block for an open circuit. If battery voltage is present, see Code P012 in G - TESTS W/CODES article in the ENGINE PERFORMANCE section.

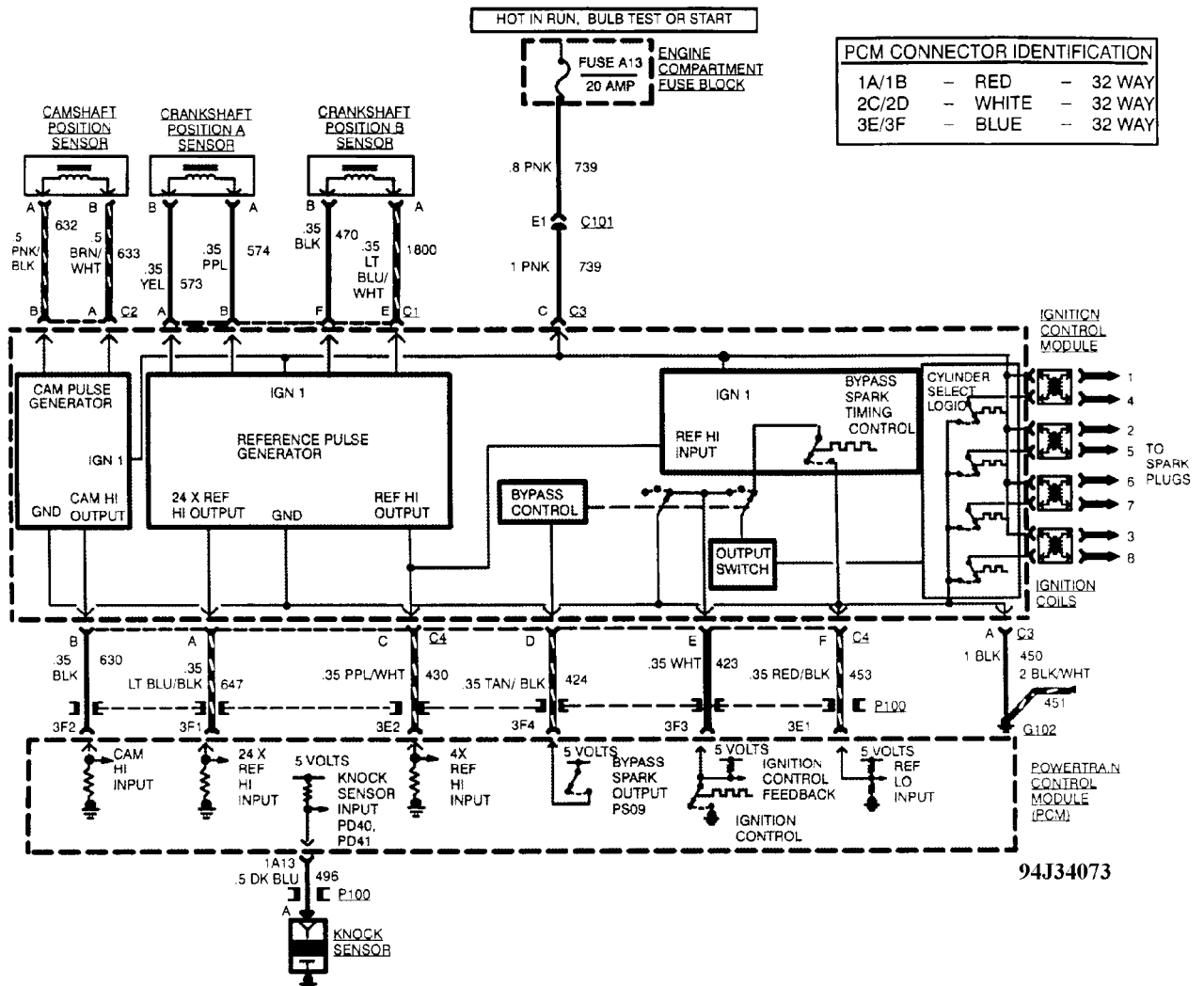

Fig. 4: 4.6L (VIN Y & 9) Ignition System (DeVilleville & Seville)
Courtesy of General Motors Corp.

Fuel System

Before checking fuel system for a no-start condition, check

ignition for adequate spark. Check for proper fuel pump pressure and capacity. See BASIC FUEL SYSTEM CHECKS in this article and INJECTOR BALANCE/COIL TEST in I - SYSTEM & COMPONENT TESTING article in the ENGINE PERFORMANCE section.

BASIC FUEL SYSTEM CHECKS (A-7)

CAUTION: Fuel system trouble shooting and diagnosis begins with checking fuel injection system pressure. High fuel pressure may be present in fuel lines and component parts. Relieve fuel pressure before disconnecting any fuel system components.

FUEL SYSTEM PRESSURE TEST

Fuel Pressure Relief

Fuel system is under pressure. Pressure must be relieved prior to servicing fuel system. Fuel pressure may be relieved by using one of the following methods.

- * On all models, disconnect fuel pump at rear body connector. Start engine and run engine until it stalls. Crank starter for 3 seconds to remove remaining fuel from fuel lines. Turn ignition off. Reconnect rear body connector.
- * Install Fuel Pressure Gauge (J-34730-1) on fuel pressure connector of fuel rail.

Fuel Pressure Check

1) Relieve fuel pressure as previously described in FUEL PRESSURE RELIEF. Connect Fuel Pressure Gauge (J-34730-1) to fuel pressure fitting on fuel rail. With gauge installed, turn ignition on. With ignition on and engine off, fuel pressure should read within specification. See FUEL PRESSURE table. If no fuel pressure is present, go to step 5).

2) Start engine. Pressure should drop 3-10 psi (.2-.7 kg/cm²). Turn ignition off. Pressure should hold. If pressure does not hold, check for leaking injectors or fittings. If injectors or fittings are not leaking, replace pressure regulator.

3) If pressure is present but less than specification, check for restricted delivery line or fuel filter. Repair as necessary. If no restriction is evident, apply battery voltage to fuel pump test connector using a 10-amp fused jumper wire. For location of fuel pump test connector, see COMPONENT LOCATIONS in appropriate I - SYSTEM & COMPONENT TESTING article in the ENGINE PERFORMANCE section.

4) Gradually pinch off fuel return line between gauge and fuel tank. If fuel pressure increases to within specification, replace fuel pressure regulator. If fuel pressure does not increase with line

pinched, check for faulty in-tank fuel pump or partially blocked fuel strainer.

5) Apply battery voltage to fuel pump test connector using a 10-amp fused jumper wire. For location of fuel pump test connector, see COMPONENT LOCATIONS in I - SYSTEM & COMPONENT TESTING article in the ENGINE PERFORMANCE section. Observe fuel pressure reading. If fuel pressure is still not present, check wiring between test connector and fuel pump. If wiring is okay, replace fuel pump.

6) If fuel pressure is present with voltage applied to test connector, test fuel pump relay and voltage supply to relay. See I - SYSTEM & COMPONENT TESTING article in the ENGINE PERFORMANCE section.

FUEL PRESSURE TABLE

Application	psi (kg/cm ²)
4.6L & 4.9L	40-50 (2.81-3.50)

Fuel Pump Relay

See MOTORS, RELAYS & SOLENOIDS in appropriate I - SYSTEM & COMPONENT TESTING article in the ENGINE PERFORMANCE section.

Fuel Pump Relay By-Pass Procedure

See FUEL DELIVERY in I - SYSTEM & COMPONENT TESTING article in the ENGINE PERFORMANCE section.

BASIC IGNITION SYSTEM CHECKS (C-4)

HEI-EST DISTRIBUTOR

NOTE: The only adjustments that can be made to HEI/EST ignition system are basic ignition timing (on distributor-type ignitions) and spark plug gap.

Spark

1) If factory tachometer is connected at coil tachometer terminal, disconnect it before performing tests. When removing spark plug wire from spark plug, twist and pull on boot (not on wire).

2) Using Spark Tester (ST-125), check for spark at coil wire (if applicable) and at each spark plug wire using spark tester. Check spark plug wire resistance on suspect wires. Resistance should be less than 30,000 ohms.

Ignition Coil Power Source

1) Turn ignition on. Using voltmeter, check voltage between F-BASIC

terminal "+" of ignition coil and ground on models with remote-mounted coil.

2) On models equipped with integral ignition coil, check voltage between BAT terminal and ground at distributor. Battery voltage should exist. If battery voltage does not exist, check for open circuit, blown ignition fuse or defective ignition switch.

Ignition Coil Resistance

1) Turn ignition off. Remove distributor cap and coil assembly. Invert cap. See Fig. 5. Set ohmmeter to low scale. Connect leads to coil BAT and TACH terminals. Resistance should be zero or nearly zero. If resistance is not zero or nearly zero ohms, replace ignition coil.

2) Set ohmmeter on high scale. Connect one lead to coil secondary terminal and other lead to ground terminal. If resistance reading is infinite, replace ignition coil.

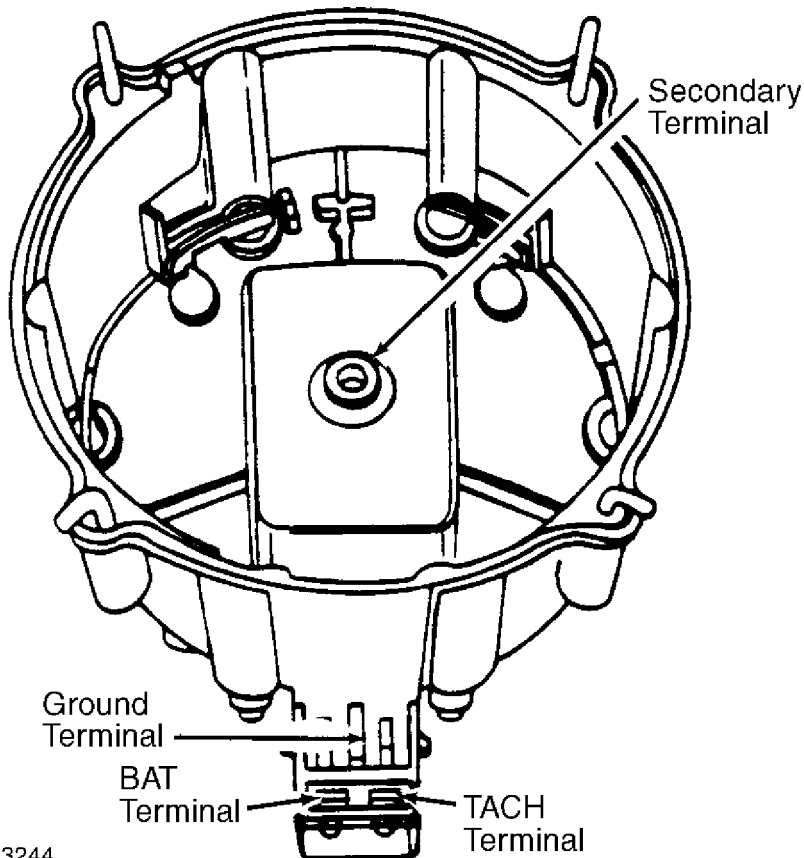

90B13244

Fig. 5: Testing Ignition Coil Resistance (Internal Coil)
Courtesy of General Motors Corp.

Distributor Pick-Up Coil Short & Resistance Checks

1) Disconnect pick-up coil leads from HEI/EST module terminals "N" and "P". Set ohmmeter to middle scale. Connect one ohmmeter lead to either pick-up coil lead and the other lead to

distributor housing. Flex pick-up coil leads by hand to check for intermittent shorts to ground. Reading should be infinity at all times. If resistance is not infinite, replace pick-up coil.

2) Connect ohmmeter between both pick-up coil leads. Check for intermittent open circuit by flexing wires and connectors. Resistance should be 500-1500 ohms. If resistance is not as specified, replace pick-up coil.

Tach Pulse (RPM) Signal

1) Connect a scan tester to the DLC. RPM should be indicated on tester when engine is cranked or running. If scan tester is not available, tach pulse (RPM reference from ignition module) will be indicated as a voltage signal on a DVOM (with a minimum 10-megohm input impedance) when DVOM is touched to PCM terminal circuit No. 430 with engine cranking.

2) A tach pulse signal may be simulated (to test PCM response) by connecting a test light in series between battery and PCM terminal circuit No. 430. Each time test light is touched to and removed from circuit No. 430, PCM will see this as a tach signal. For circuit and terminal reference, see appropriate schematic under NO START - ENGINE CRANKS OKAY.

Hall Effect Switch (4.9L)

1) Disconnect distributor 4-wire and 6-wire connectors. Apply battery voltage to Red wire of 3-wire distributor connector (distributor side). Connect ground to Black wire of 3-wire distributor connector (distributor side).

2) Connect voltmeter positive lead to terminal "E" (Brown/White wire) of 5-wire distributor connector (distributor side). Connect voltmeter negative lead to terminal "D" (Black/Red wire) of 5-wire distributor connector (distributor side).

3) Bump starter and note voltmeter reading. When distributor blade is in window of Hall Effect switch, voltmeter should read within .5 volt of battery voltage. When distributor blade is not in window of Hall Effect switch, voltmeter should read less than .5 volt. Bump starter several times to cause both conditions to occur.

4) If Hall Effect switch is functioning properly and starter is cranked, voltmeter should show an averaged voltage of about 5-6 volts. If Hall Effect switch does not function as described, replace Hall Effect switch.

DIS (4.6L)

Spark

1) If factory tachometer is connected to coil tachometer terminal, disconnect tachometer before performing tests. When removing spark plug wire from spark plug, twist and pull on boot, NOT on wire.

2) Using Spark Tester (ST-125), check for spark at each spark

plug wire using spark tester. Leave other wires connected while checking for spark. Check spark plug wire resistance on suspect wires. Resistance should be less than 30,000 ohms (12,000 ohms on 1.9L).

Ignition Coil Power Source

Turn ignition on. Check Pink/Black or Pink wire of ignition module for battery voltage. If battery voltage is not present, check ignition or PCM fuse. If fuse is not blown, check for open between fuse and ignition module.

Ignition Coil Resistance (Except 1.9L)

If ignition coil is suspected of causing misfire or no-spark condition, switch coil locations on DIS module. If problem follows questionable coil, check ignition coil resistance or replace original coil. For ignition coil resistance, see IGNITION COIL RESISTANCE table.

IGNITION COIL RESISTANCE TABLE

Application	Ohms
Primary	(1)
Secondary	(1)

(1) - Information not available from manufacturer. Refer to NO START DIAGNOSIS (A-3).

AA

Crankshaft Sensor Pick-Up Coil Short & Resistance Checks

1) Set DVOM on 2000-ohm scale position. Connect DVOM leads to crank angle sensor connector, located on side of engine block. Turn ignition off. Disconnect ignition module connectors. Measure resistance between crankshaft sensor terminals at ignition module connector.

2) Crankshaft sensor resistance should be within specification range listed in CRANKSHAFT SENSOR RESISTANCE table. If resistance is not as specified, replace sensor. If sensor is within specification, go to next step.

3) With sensor installed in block, connect one ohmmeter lead to either sensor terminal at ignition module. Touch other lead of ohmmeter to engine block. No continuity should exist. If continuity exists, sensor or harness is shorted to ground and must be repaired or replaced.

CRANKSHAFT SENSOR RESISTANCE TABLE

Application	Ohms
-------------	------

4.6L (1)

(1) - Information not available from manufacturer.

AA

Crankshaft Sensor Output Signal

Set DVOM on 2-volt AC scale. Connect voltmeter leads to crankshaft sensor installed in side of engine block. Crank engine and observe voltmeter reading. Crank angle sensor should generate a voltage signal of about .05 volt at slow cranking speed to greater than .1 volt (100 mV) at high cranking speed. With engine running, voltage signal will be much greater.

Tach Pulse (RPM) Signal

Connect scan tester to DLC. RPM should be indicated on tester when engine is cranked or running. Tach pulse (RPM reference) will be indicated as a voltage signal when a DVOM (with a minimum 10-megohm input impedance) is used to backprobe RPM "high reference" circuit. For circuit and terminal reference, see appropriate schematic in NO START - ENGINE CRANKS OKAY.

IDLE SPEED & IGNITION TIMING

Ensure idle speed and ignition timing are set to specification. For adjustment procedures, see appropriate D - ON-VEHICLE ADJUSTMENTS article in the ENGINE PERFORMANCE section.

DIAGNOSTIC CIRCUIT CHECK

NOTE: On 4.6L and 4.9L models, see G - TESTS W/CODES article in the ENGINE PERFORMANCE section.

SUMMARY

If no faults were found while performing BASIC DIAGNOSTIC PROCEDURES, no trouble codes (or only intermittent ones) were found while performing DIAGNOSTIC CIRCUIT CHECK and driveability problems exist, proceed to H - TROUBLE SHOOTING - NO CODES article in the ENGINE PERFORMANCE section for diagnosis by symptom (i.e., ROUGH IDLE, NO-START, etc.) or intermittent diagnostic procedures.

WIRING DIAGRAMS

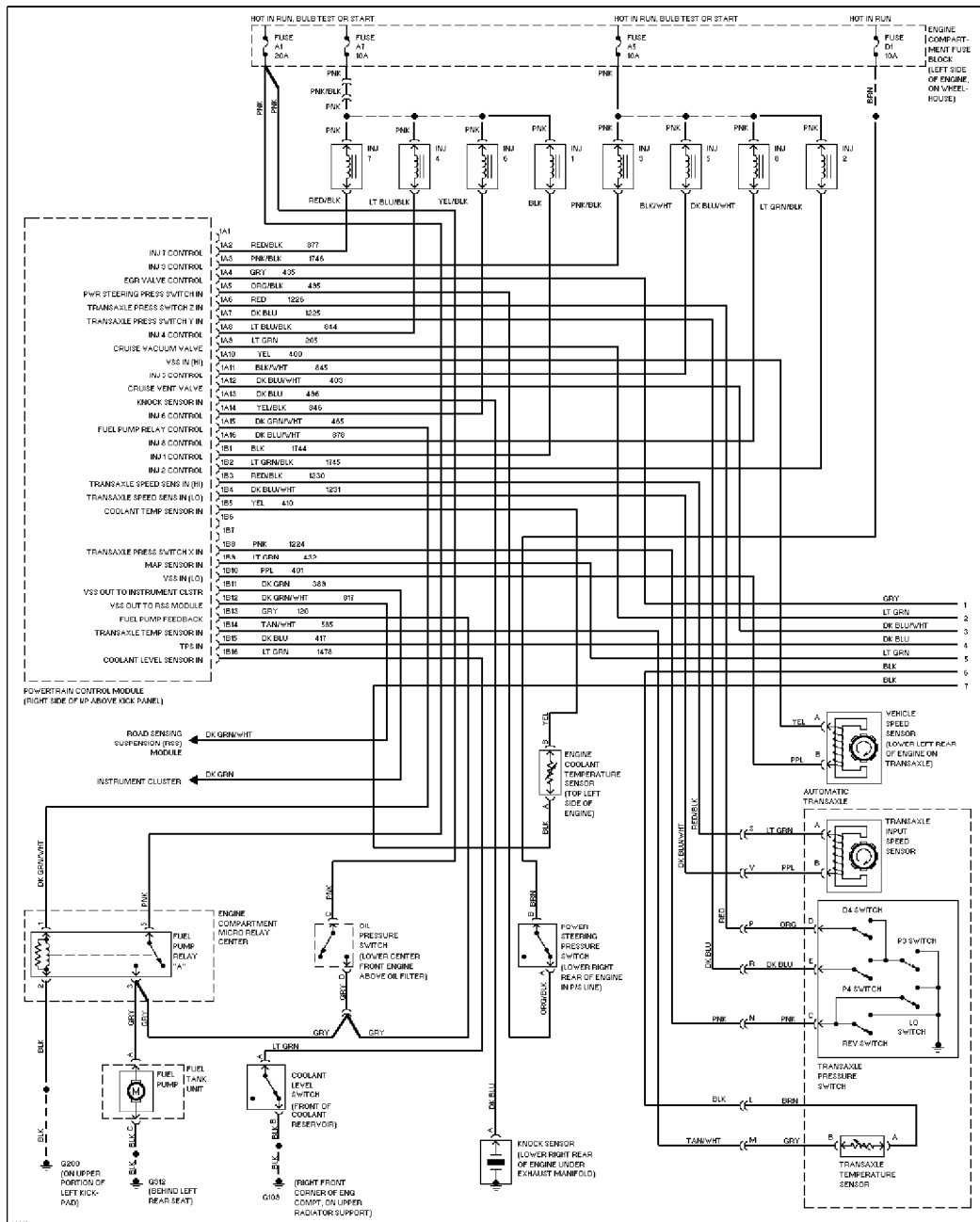

Fig. 6: 4.6L (VIN Y & 9) PCM Wiring Diagram (Concours & Seville - 1 Of 3)

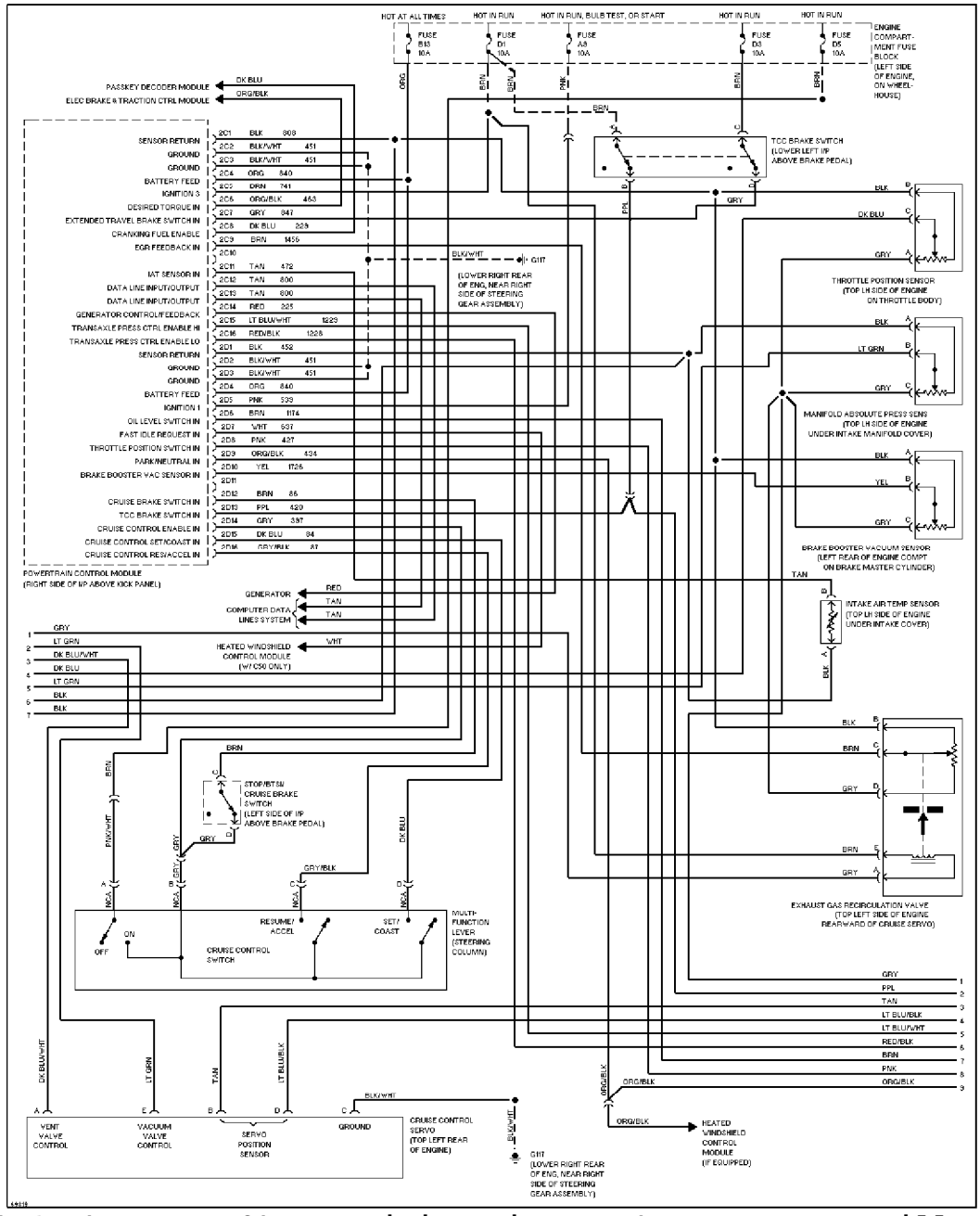

Fig. 7: 4.6L (VIN Y & 9) PCM Wiring Diagram (Concours & Seville - 2 Of 3)

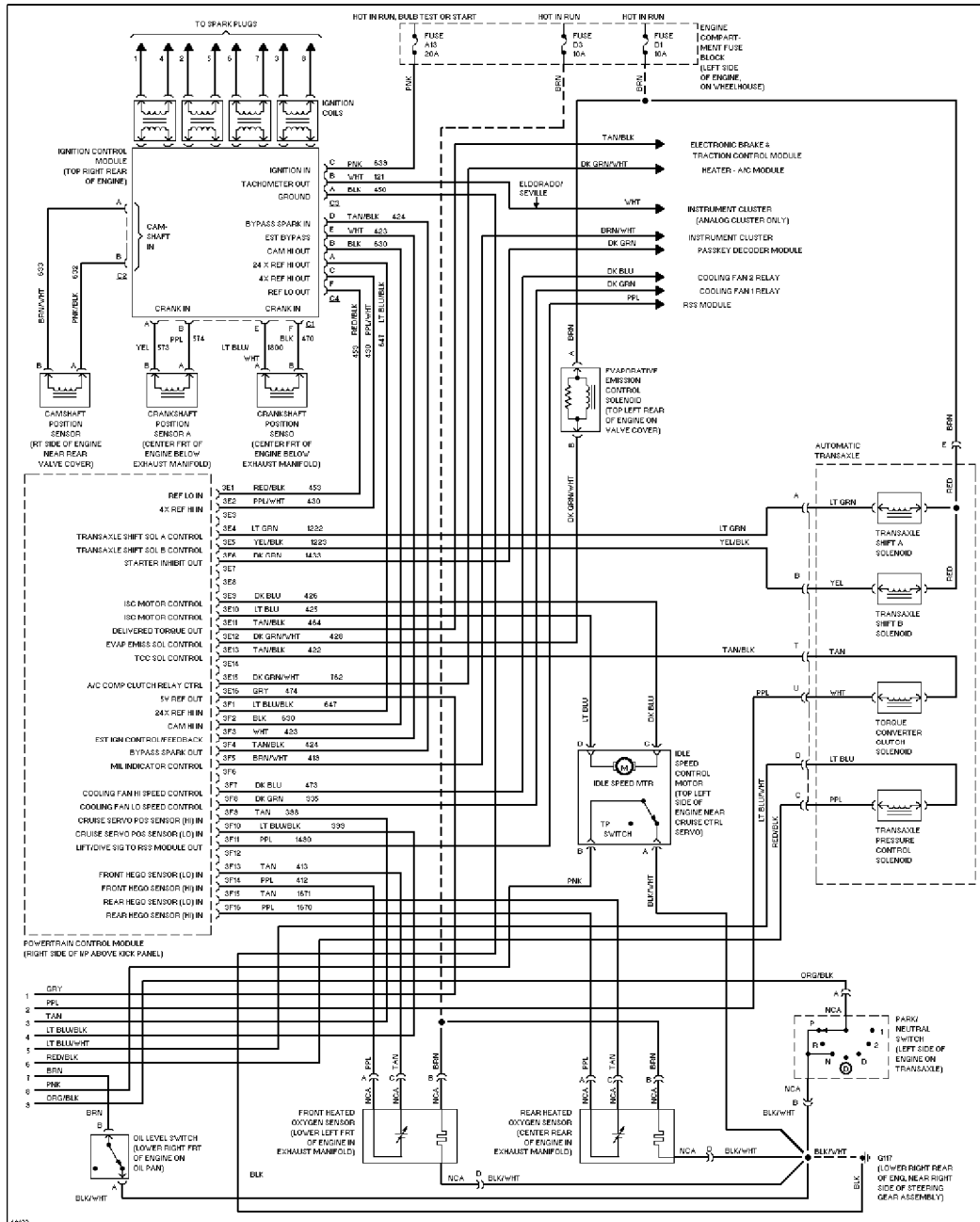

Fig. 8: 4.6L (VIN Y & 9) PCM Wiring Diagram (Concours & Seville - 3 Of 3)

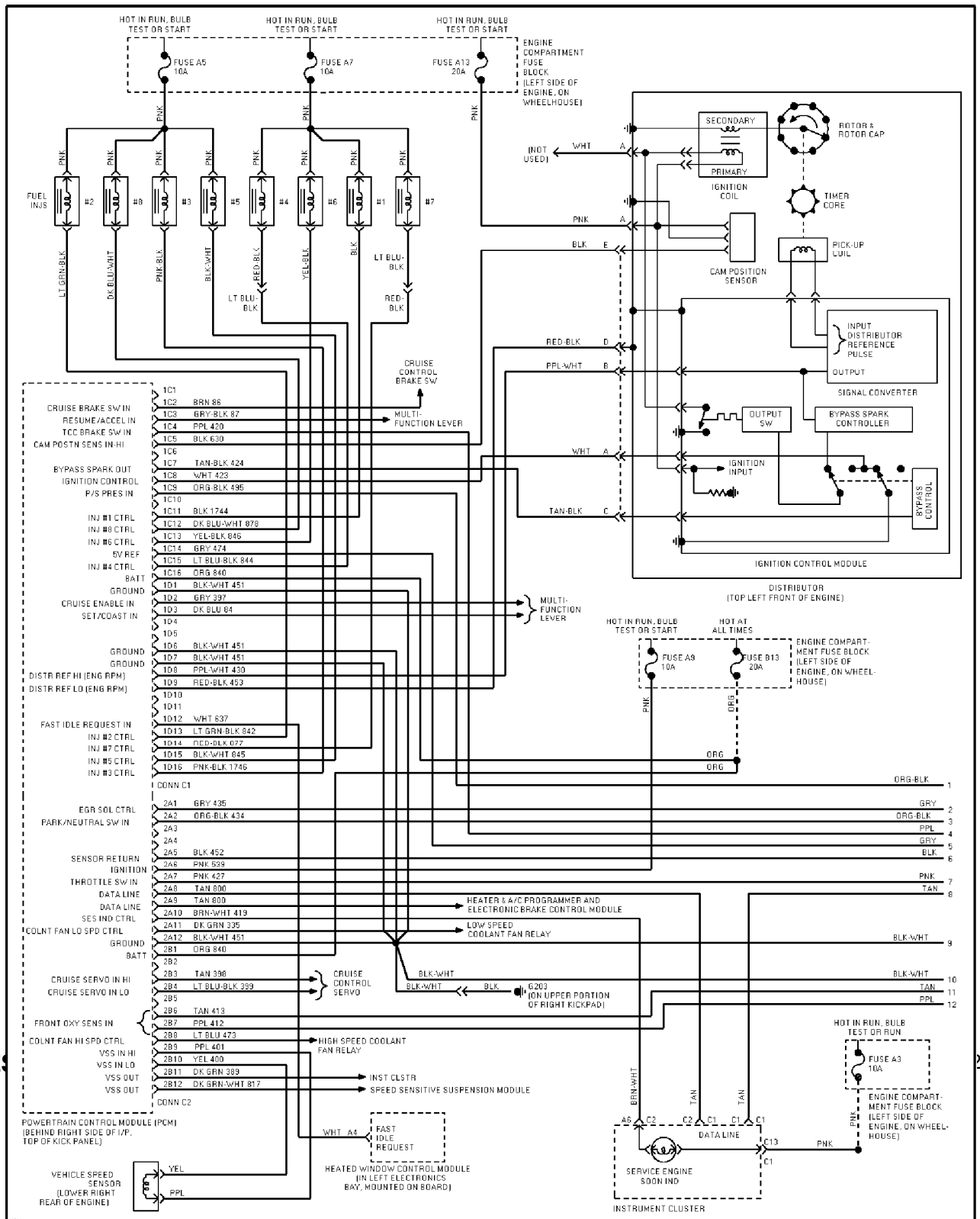

Fig. 9: 4.9L (VIN B) PCM Wiring Diagram (DeVille - 1 Of 3)

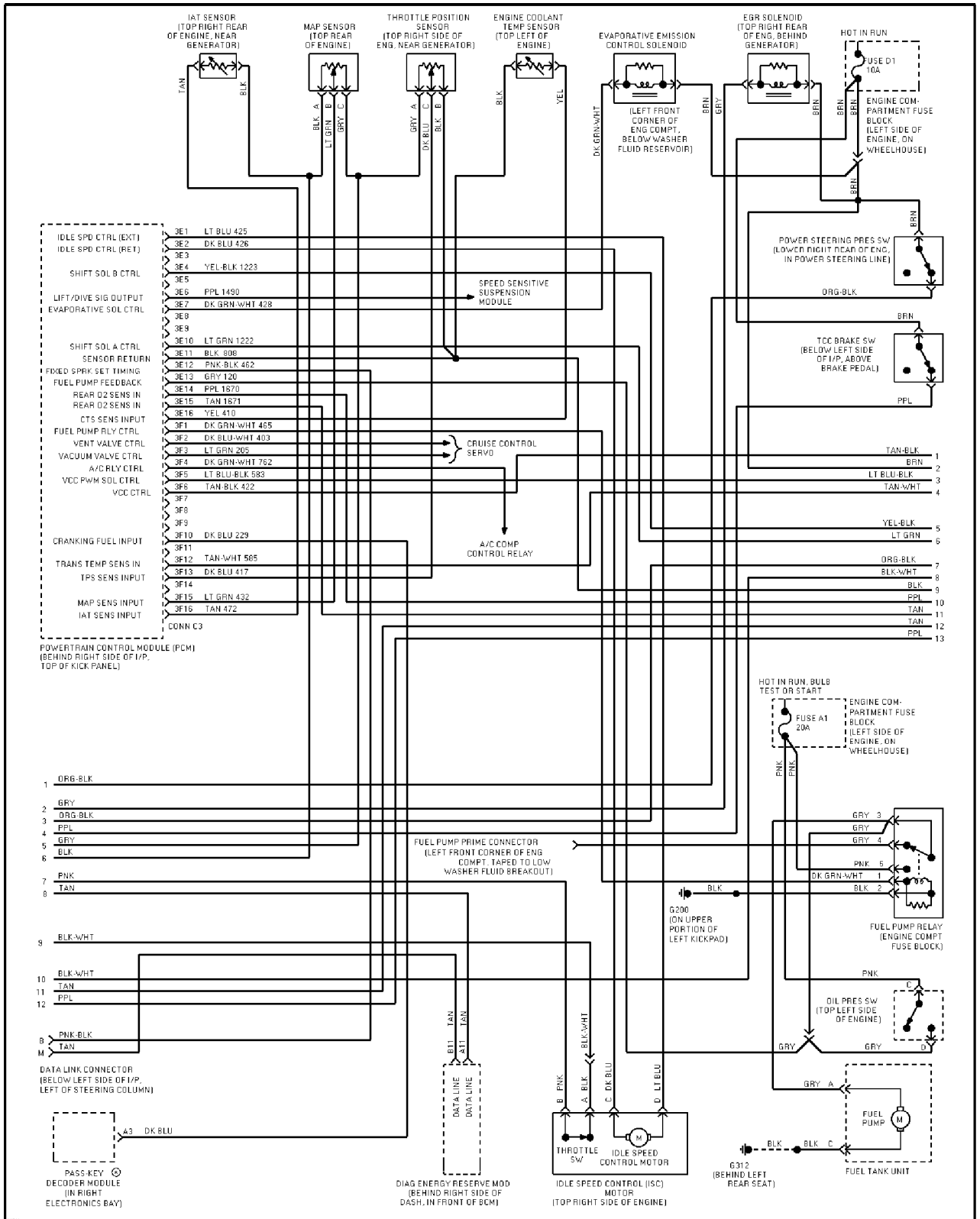

Fig. 10: 4.9L (VIN B) PCM Wiring Diagram (DeVil - 2 Of 3)
F - BASIC TESTING Article Text (p. 21) 1995 Cadillac Concours For Ace Mechanics 123 Main Street San Diego Ca 9212

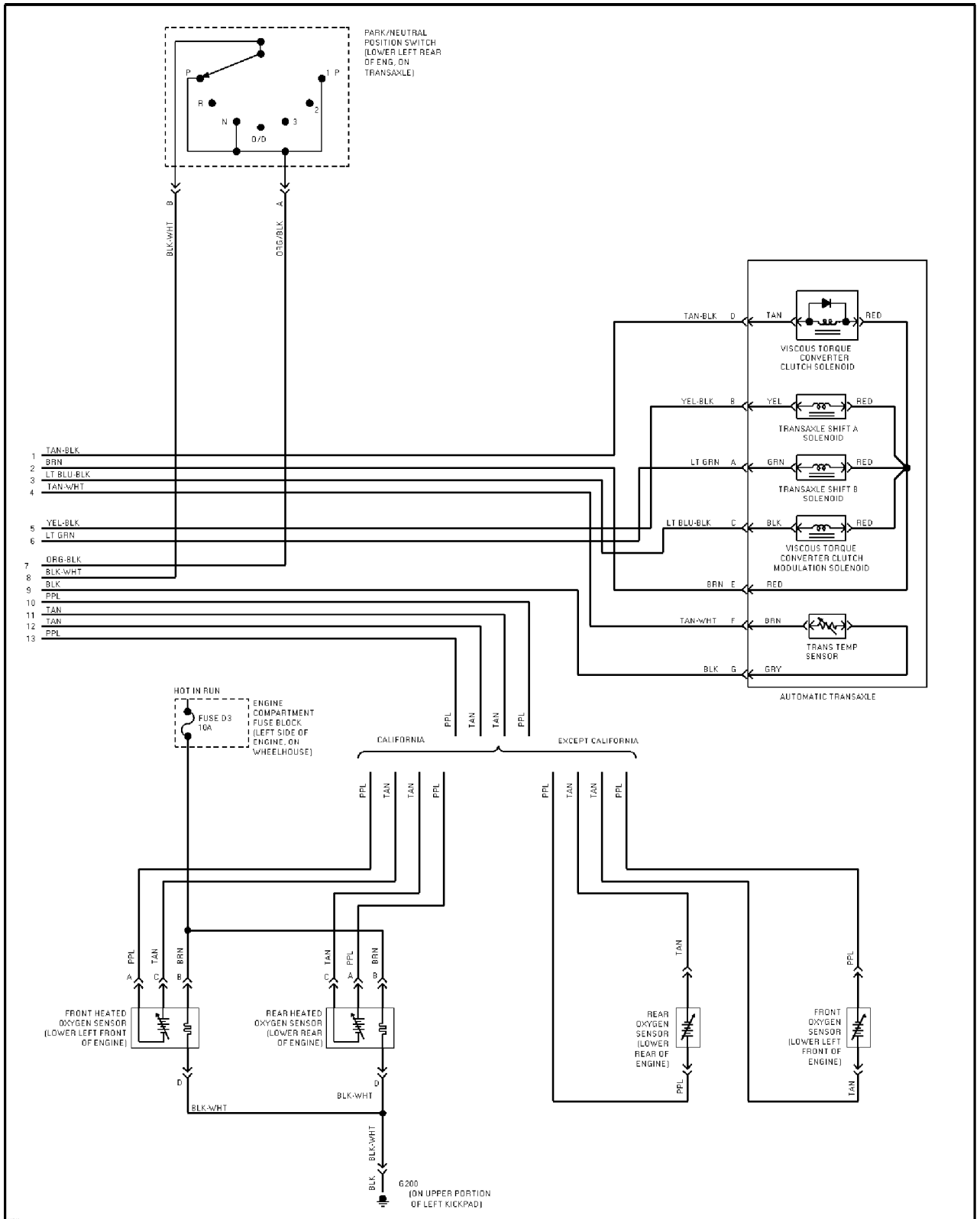

Fig. 11: 4.9L (VIN B) PCM Wiring Diagram (DeVille - 3 Of 3)

END OF ARTICLE